

super
® TECHNICA

4 x 5 in.

9 x 12 cm

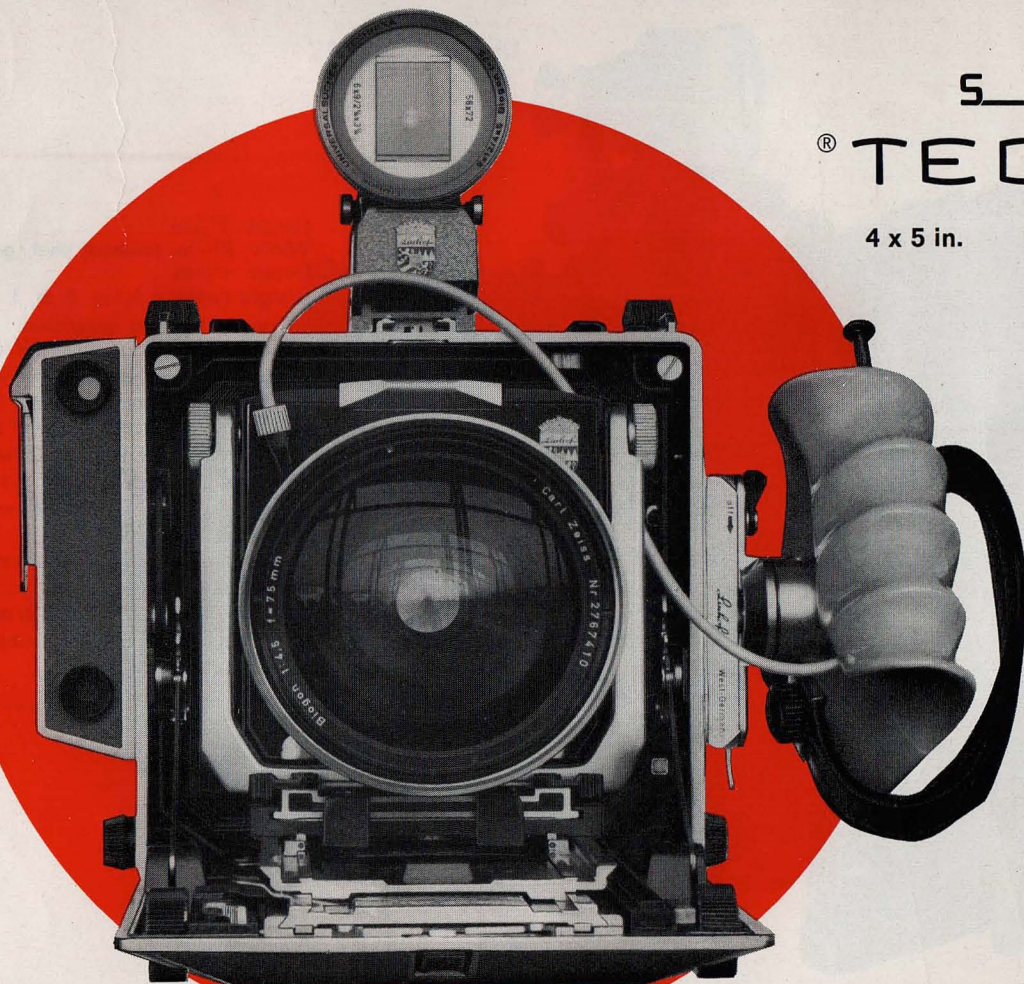

Operating Manual



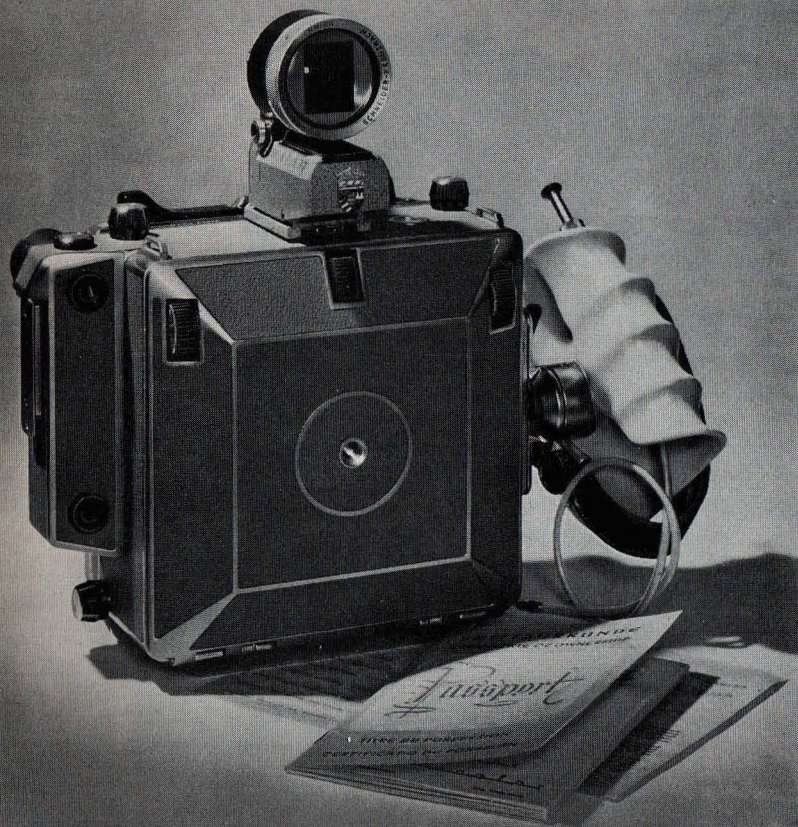

Before you start using your new camera . . .

. . . please take the time to get acquainted with its many unique features and smooth operations described in the following pages. Your SUPER TECHNIKA is ruggedly built in the best Linhof tradition. Yet, it is a precision instrument, and you should treat it as such. Make it a habit to protect your camera from dust, sand, or spray, and avoid rough handling. This will insure readiness, consistently reliable performance, and lasting service. All movable parts are free from the necessity of continuous servicing. Keep gliding parts, such as upper track, always absolutely clean. You may apply a very thin film of chemically pure vaseline to the upper track. Under no circumstances should oil be used! After continuous intensive use, periodic inspection and servicing is as important for your camera as it is for your car. Your Linhof dealer or the nearest Linhof service department are always ready to serve you in every possible way.

Please make sure that you receive together with your outfit the camera passport. The guarantee registration card contained therein should be filled in and mailed to Linhof immediately to validate the guarantee.

Upon receipt of the registration card, a free sample copy of the famous quarterly magazine INTERNATIONAL PHOTO TECHNIK (Grossbild-Technik) will be mailed to you. In addition, our customer service department will send you information on new Linhof equipment etc. from time to time. We would also like to draw your attention to such specialized publications as the LINHOF PRACTICE, TECHNIQUES OF ADVERTISING PHOTOGRAPHY, and APPLIED PHOTOGRAPHY. Further information on the complete range of publications of large format photography may be obtained from VERLAG GROSSBILD-TECHNIK GMBH, 8 München 25, Rupert-Mayer-Straße 45.

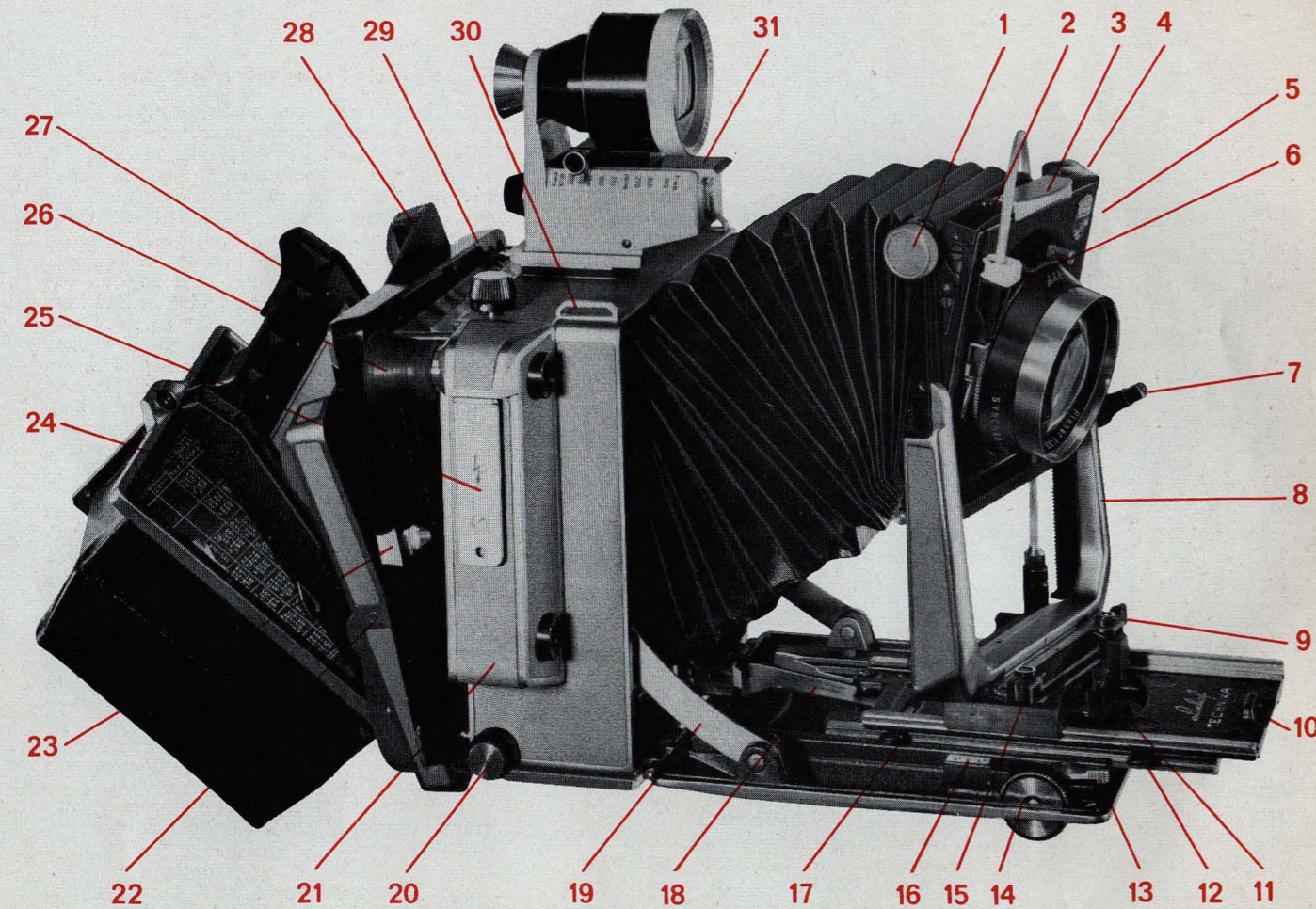

Keep this page folded out when reading instructions, so that you can easily identify the numbered operating parts.

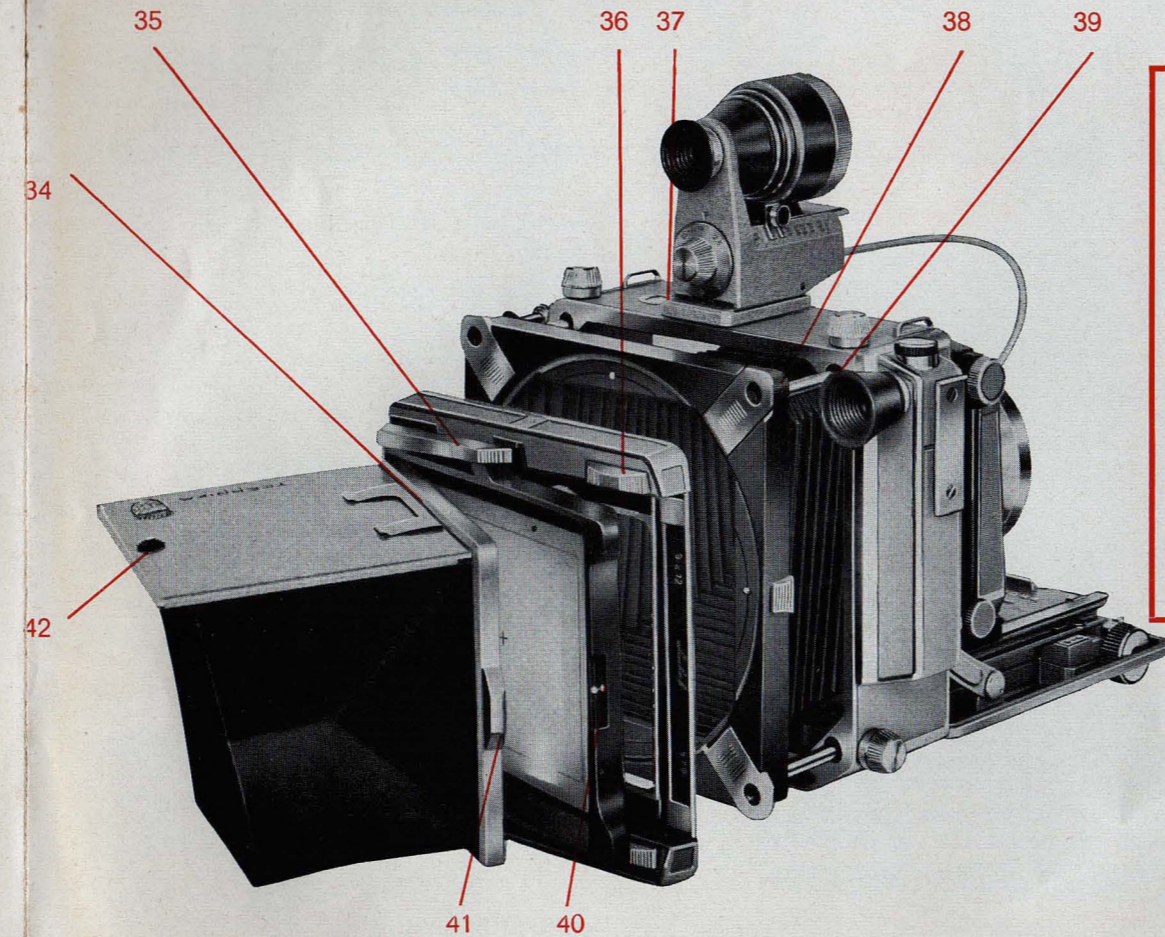

Specifications:

Height: $7\frac{1}{4}$ in.
 Width: $8\frac{3}{5}$ in. (without anat. grip)
 Depth: $4\frac{1}{3}$ in.
 Weight (without lens): 6 lb. 1 oz.
 Maximum bellows extension: $15\frac{3}{4}$ in.
 Camera back extension: $1\frac{3}{8}$ in.
 Drop-bed inclination: 15° and 30° beyond normal drop of 90°
 Maximum rise of front: $2\frac{3}{16}$ in.
 Lateral shift, each way: 1 in.
 Lens tilt: approx. 15° each way, forward and backward
 Lens swivel: approx. 15° each way
 Swing of camera back: approx. 15° to each side
 Technical specifications subject to change without notice.

Operating Parts and Components

1. Locking screw for lensboard tilt
2. Sockets for wire-frame finder and Color compendium, as well as gelatine filter holder
3. Locking bar for interchangeable lensboard
4. Release button for forward and backward tilt through the center of the horizontal axis
5. Lensboard (flat or recessed)
6. Rapid-lock cable release socket
7. Lift lever for operating rising front
8. Lens standard frame with racks
9. Release lever for front swivel through vertical axis
10. Pull-out grip for upper track
11. Spring-tensioned grips for pulling out lens standard
12. Release for full extension and retraction for upper track
13. Locking lever for track extension
14. Rack-and-pinion focusing knob (right and left)
15. Locking and release lever for lateral shift with zero click-stop
16. Two-pin socket for cable release
17. Release for pushing back the upper track when using wide-angle lenses or for pulling it forward for triple extension
18. Cam shoe with rangefinder coupling cam
19. Three position bed struts
20. Locking knobs (4) for swing-back
21. Multifocus rangefinder for lenses from 75 mm (3 in.) to 360 mm (14 in.) focal length
22. Position mark of focal plane
23. Swing frame zero lock
24. Folding focusing hood, detachable
25. Bracket for flash unit or right-hand anatomical grip
26. Rangefinder rubber eyepiece
27. Spring-tensioned groundglass frame with groundglass
28. Revolving frame
29. Swing-frame
30. Eyelets for shoulder strap
31. Multifocus optical viewfinder (optional accessory); $\frac{3}{8}$ in. tripod bushing situated under removeable accessory shoe
32. Spring-clip to hold dark slide
33. Spring-tensioned arms to hold groundglass frame
34. Sliding locks to hold Rollex or other accessories
35. Built-in spirit level
36. Slide (4) to hold revolving frame on swing frame
37. Guiding pins of swing frame
38. Snap button to hold focusing hood frame
39. Pull-out handle for focusing hood frame
40. Sliding button to open focusing hood

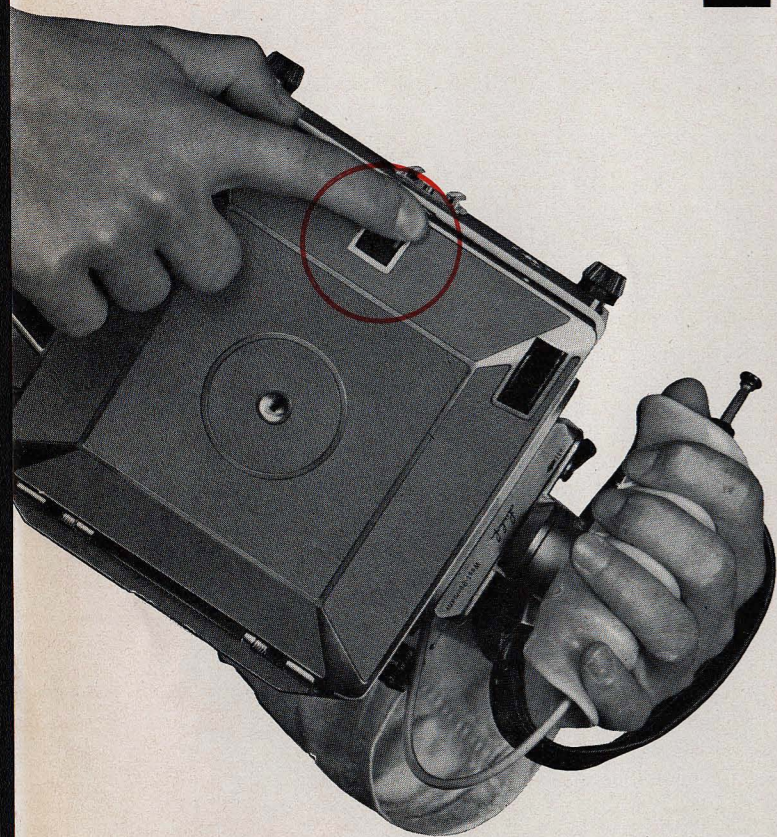

1

2

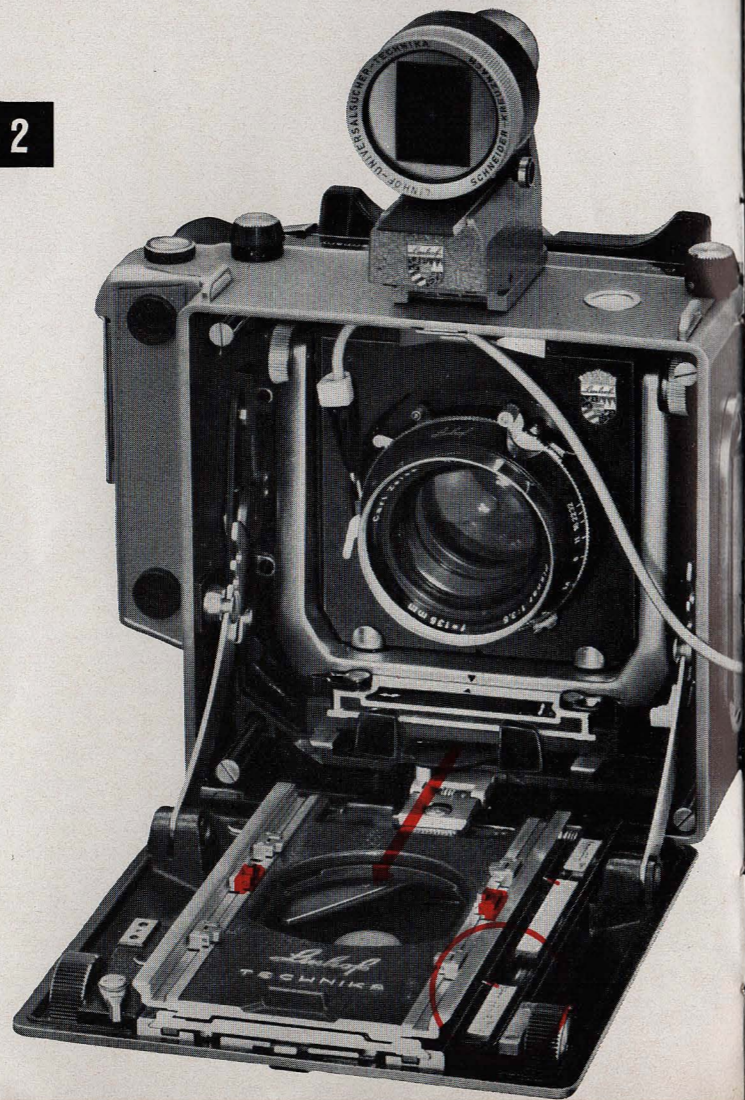

Technika V 4 x 5 without rangefinder

This following operating manual also applies to the Technika Camera Model V without rangefinder, with exception of instructions on page 13

1

Opening and Closing the Camera

To open the camera, push the drop-bed release catch down (ill. 1). Let the drop-bed down 90° until the bed struts click into the first notch (ill. 2).

When you close the camera after use, please make sure that it is in the same position as it stands now before you. All swings and tilts must have been returned to zero and the lens standard must be pushed back all the way into the camera body. The focusing tracks must be all the way back in infinity position. Lenses of extra long constructional design (such as tele-photo lenses) must be removed from the camera before closing. The cable release must be separated from the shutter. This is easily done by operating the rapid-lock cable release socket. Without danger to the rangefinder linkage, the camera may also be closed without coupling cam inserted, (e. g. after groundglass focusing resp. after using an extreme wide-angle lens).

2

Infinity Position

The upper track is fitted with fold-up stops which establish the infinity position for the lens standard. One pair of parallel stops belongs to each lens used on the camera. Infinity stops for different lenses have different colors for easy identification: Red is the distinguishing color for the normal, black for the wide-angle, and green for the tele-photo lens. If more lenses are installed, additional colors such as yellow or blue will be used. Grasp the lens standard by the pull-out grips, (11) press them inward and pull the lens standard out on the upper track against the desired infinity stops, which have been folded up before. The camera is now set for infinity. When using a standard long focus lens from 240 mm up or a telephoto lens of 360 mm, it is in addition required to pull out the upper track to the secondary stop after pressing down the release (17). For such lenses, the distance scale located near the front edge of the drop-bed applies (encircled). The red index of the drop-bed is now located on the infinity mark of the distance scale. The distance scale stage carries up to 3 scales, one each for wide angle, normal, and telephoto lenses. Their color corresponds with the color of the infinity stops and rangefinder coupling cams. When more than 3 lenses are used on the camera, the scale stage may be exchanged for another one carrying additional scales simply by pulling it off its dovetail.

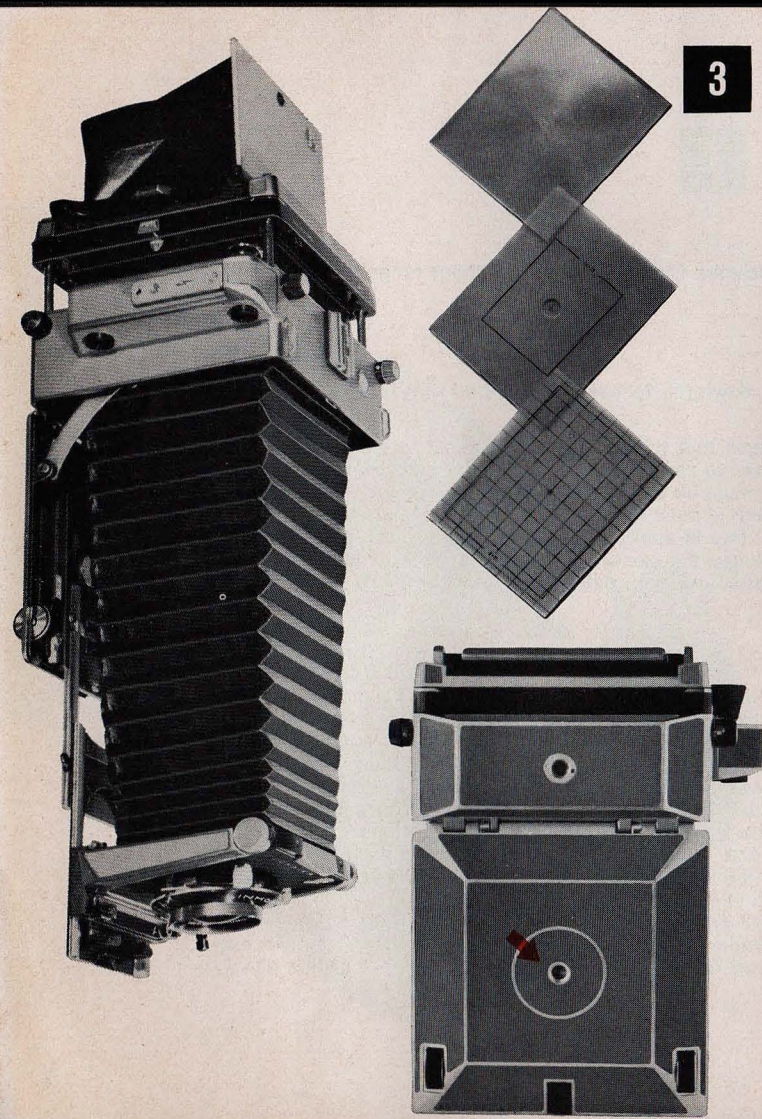

3



4

3

Triple Extension

To focus on subjects closer than infinity, rotate the right or left focusing knob (14). To obtain additional bellows extension (for extreme close-ups, macro photography etc.), first disconnect the cable release from the socket on the lensboard, and also detach it from anatomical grip. Then hold down the track catch (12) and pull the upper track forward until it clicks into position. Use the focusing knobs (14) for fine focusing on the ground glass. Reconnect the cable release to the rapid-lock socket on the lensboard. After focusing is completed, it is recommended to operate the track locking lever (13). This is particularly important when using the camera in a vertical position. To return the upper track to its normal position, hold down the catch (12) while you slide the track back until it clicks into place. To avoid a possible camera vibration with long bellows extensions, it is recommended to use the second tripod bushing located in the middle of the drop-bed (see illustration 3, below). The use of this tripod bushing also permits the rotating of the camera back and the dropping of the camera bed (wide angle position) when the camera is mounted on a pan/tilt head.

4

Ground Glass Focusing

Ground glass focusing and composition is required when camera adjustments become necessary.

After setting the lens for infinity, the between-lens-shutter is opened according to the shutter operating instructions packed with each lens. By pushing the sliding button (42) towards the center of the focusing hood cover, the focusing hood snaps open by spring tension. The focusing hood prevents stray light, so that a clear easily observable ground glass image becomes visible. It is always recommended to determine critical sharpness by means of the Linhof focusing magnifier (022513). Before using the magnifier, fold away the focusing hood (ill. 4). The focusing hood frame is held in place by a snap button; it is opened by pulling on the grooved tab (41). After opening, the focusing hood may be removed entirely by pressing the focusing hood frame to the right, so that it disengages from its spring loaded hinge. For precise focusing, without interference from stray light, the use of the focusing bellows (002503) or reversal mirror attachment (002628) is recommended.

In architectural photography a ground glass with centimeter grid (021805), available on request as accessory, greatly facilitates to check on vertical and horizontal lines. A very desirable accessory, especially when using short focus (wide angle) lenses, is the Ektalite field lens (002522). It provides a uniform brightness of the ground glass image, even on its edges, so that focusing and composition are greatly facilitated. Further auxiliary equipment: Focusing bellows (002503) that does away with the focusing cloth, and reversal mirror attachment (002628), both these being exchangeable against the focusing hood (please ask for special catalogues).

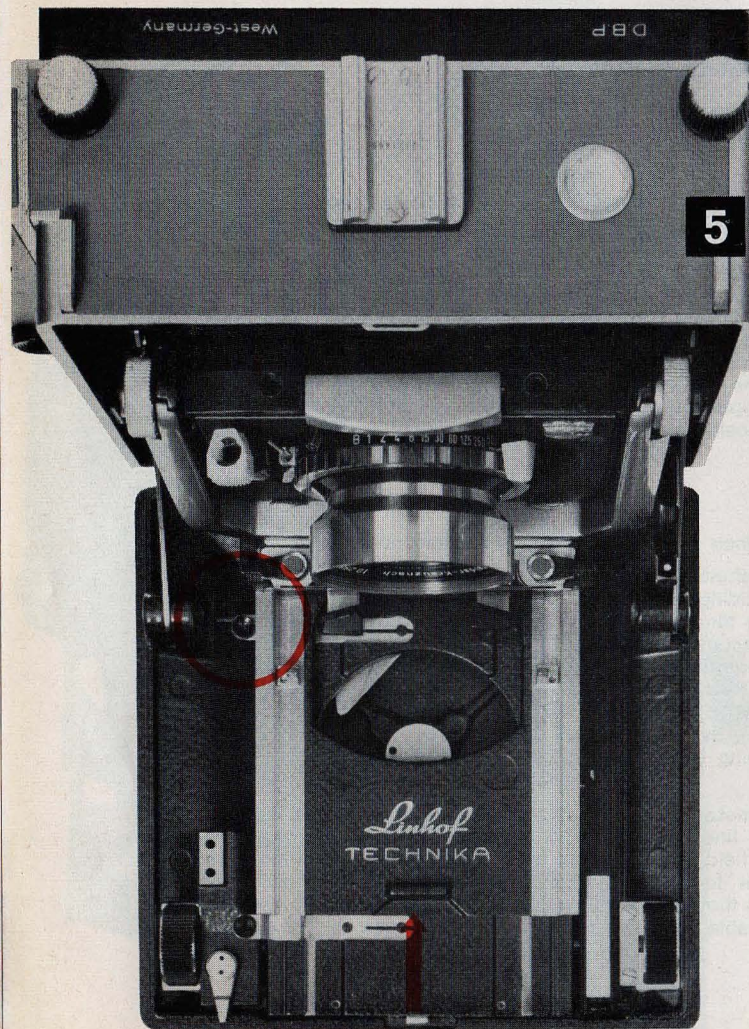

5

6

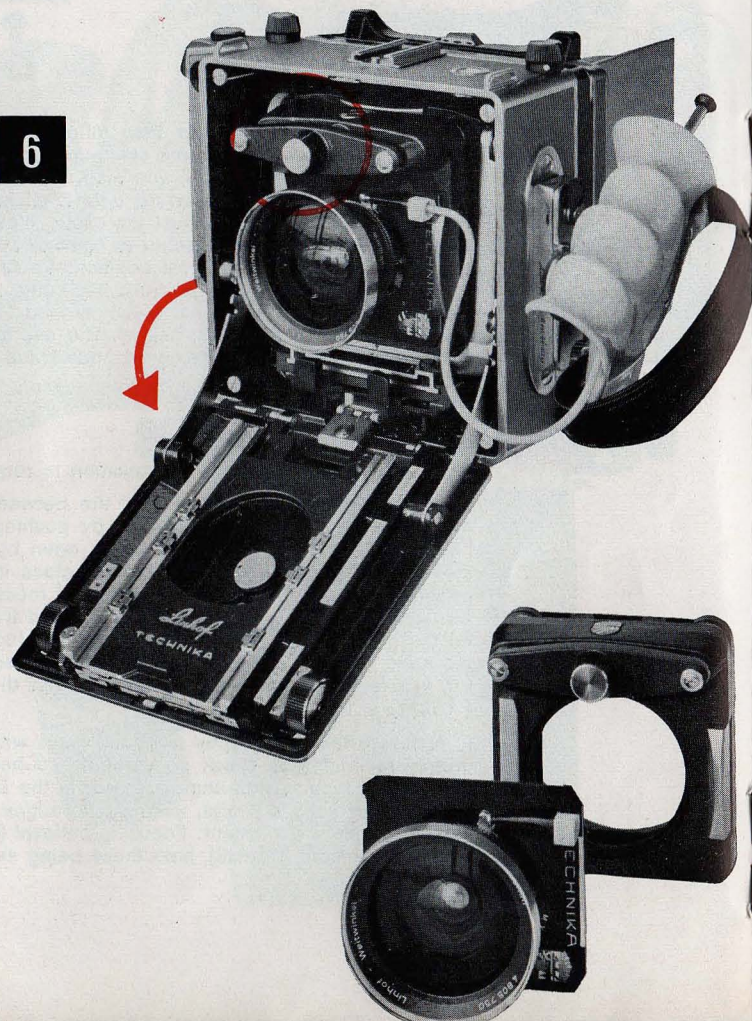

5

Wide Angle Photography

When using 75 mm and 90 mm wide angle lenses, the upper track (17) must be moved back as follows: Depress the track lock button (19) (ill. 5, red circle) just long enough to release the track, and slide the track towards the camera body until it clicks into position. When using the camera hand-held and with rangefinder focusing, the film back must be in horizontal position, in order to avoid vignetting by the front edge of the drop bed (when using the 75 mm f/4.5 Biogon, ground glass may also be used in vertical position). To take photographs in vertical position, the entire camera must be turned by 90°. This camera operation is essential when photographing with the coupled multifocus rangefinder. It is also recommended when focusing on the ground glass. In exceptional cases (vertical composition from a tripod with 75 mm or 90 mm Super Angulon without using the rising front adjustment), it is possible to proceed in the following manner, in order to avoid the need for a lateral tilt of the camera: Remove rangefinder coupling cam (except wide angle cam), press down on both struts while you lower the drop-bed 15° until it clicks into the second notch of the struts, loosen the locking knob (1) and press on the tilt release knob (4), tilt the lensboard all the way back and re-tighten the locking knob (1). Now, as described above, the upper track is pushed to its rear position. Due to the inclined position of the drop-bed, the infinity stops no longer indicate the wide angle infinity position. The lens is focused for infinity by moving the lens standard back and forth on the upper track.

6

Extreme Wide Angle Photography

When using **extreme** wide angle lenses of 58 mm to 65 mm focal lengths, a wide angle focusing device provided for these lenses is required. This makes the following additional operations necessary:

1. Remove rangefinder coupling cam as described on page 13.
2. Pull out lens standard to the middle of the upper track.
3. Exchange lens against the wide angle focusing device (ill. 6 below) fitted with the extreme wide angle lens as described on page 13.
4. Push back the lens standard into the camera body (see ill. 6).
5. Press down on both struts while you lower the drop-bed 30° until it clicks into the third notch of the struts.
6. Focus for infinity by moving the lens standard on the body track back and forth. Care should be taken that the wide angle focusing device is completely retracted. Focus for near distances by turning the focusing button (in the red circle of the wide angle focusing device).

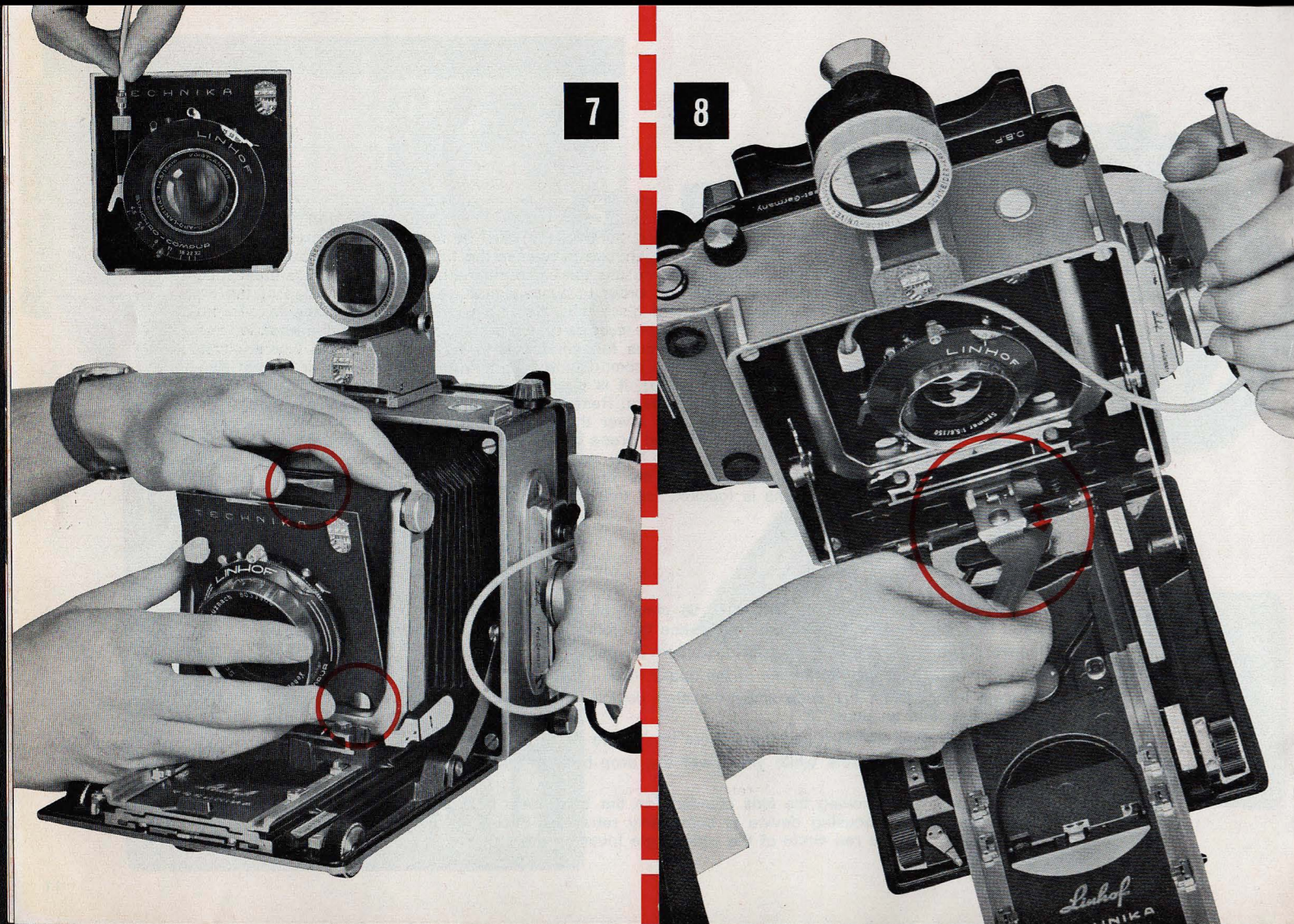

7

8

7

Interchange of Lenses

To change lenses, first remove the cable release from the shutter by pressing down the white collar of the rapid lock cable release socket (see ill. 7, above), respectively unscrew the cable release from its shutter socket if no rapid lock is provided. Attention: Safety of functioning guaranteed only when using Linhof cable releases. Hold the lens by its shutter with one hand, lift the lensboard lock (3) with the other. Now, the lens-shutter-lensboard assembly may be removed from the lens standard. The new lens is inserted with the lower edge of the lensboard into the retaining brackets (see ill. 7, lower circle) and pushed back into the standard frame while lifting the lensboard lock (3). Only then the lensboard lock should be released. The insertion of lenses of long constructional design or with large size back elements (for instance 75 mm Biogon) is greatly facilitated with a longer bellows extension. — When focusing according to the scale, the pertaining distance scale mounted on the interchangeable scale stage must be used (page 6, ill. 2), i. e. for wide angle lenses the black engraved, for normal lenses, the red, and for telephoto lenses the green scale. If more than three lenses are coupled to the camera, additional color codes are available. The scale stage is interchangeable against another one, to provide corresponding distance scales for more than 3 lenses. For focusing with the multifocus rangefinder, it is required to exchange the coupling cam together with the lens. (Before closing, lenses of long construction must be removed from the lens standard!)

8

Interchange of Coupling Cams and Rangefinder Focusing

Each rangefinder-coupled lens is supplied with a separate carefully matched coupling cam (18). On each coupling cam, both lens serial number and focal length, are engraved. Before changing the coupling cam, the lens standard must be pushed back all the way into the camera body. The upper track of the drop-bed is extended by means of the focusing knob until the coupling cam is freely accessible. Now the coupling cam (18) is slightly lifted and pulled out in a straight direction from the cam shoe (see ill. 8). When inserting a new coupling cam, please make sure to push it into the cam shoe until it comes to a positive stop. Pull out lens standard to the required infinity stops. Focusing with the rangefinder is carried out in the following way: Focus your object through the eye piece (26) of the rangefinder (21). Operate the focusing knob (14) until the double image of the rangefinder coincides completely. Looking straight through the center of the finder is of great importance. Composition for vertical or horizontal format is carried out by the optical multifocus viewfinder (31) (001306).

Even when using the camera mounted on a tripod, the rangefinder will be very useful, for instance when taking photographs of children to check critical sharpness immediately before releasing the shutter, or when taking photographs in dark interiors. When working with the optical multifocus finder and with the coupled range-finder, no camera adjustments whatsoever are possible. A very valuable accessory for hand-held work is the anatomical grip with cable-release inserted (002549). For coupling of subsequently purchased lenses, it is not necessary to return the Super Technika V to Linhof or to a Linhof service center. (Instructions for carrying out infinity adjustments are supplied with each lens purchased subsequently).

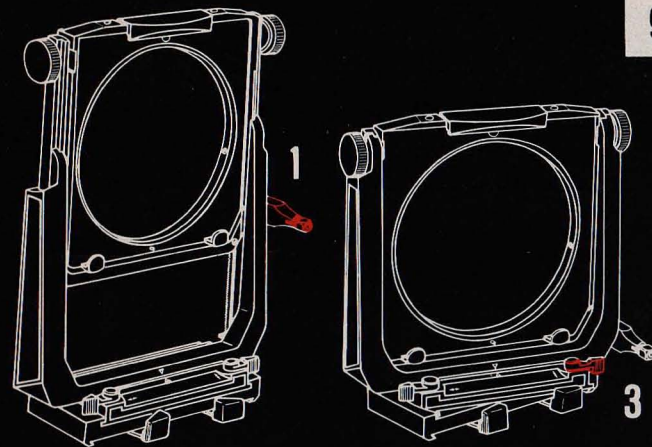

9

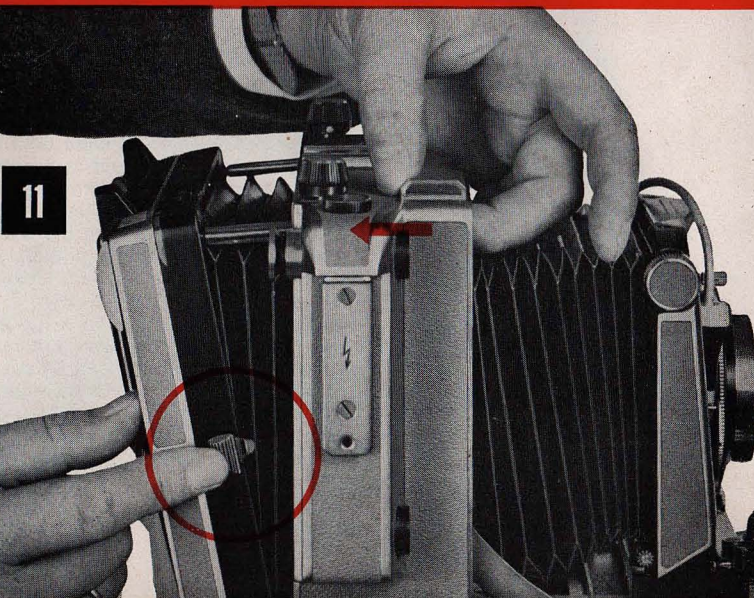
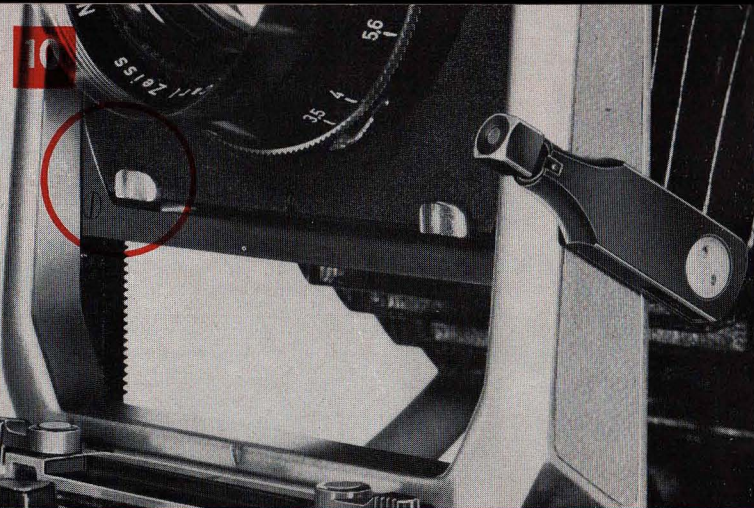
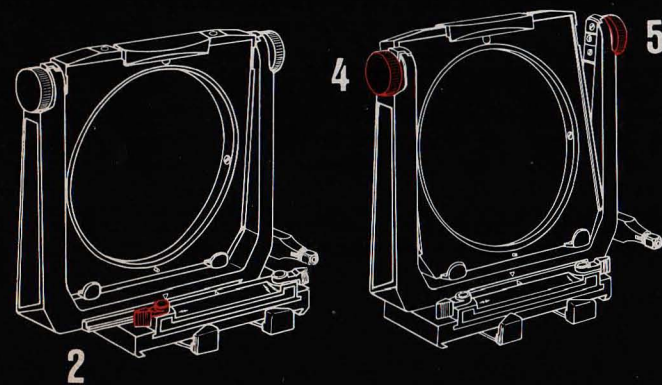

9

Adjustments of Lens Standard

1. **Rising of front** is carried out by means of the lift lever 1/ill. 9 and ill. 10, operated with the cubic shaped front grip.
This grip handle can be rotated after pulling out. If white dot on handle is on top, front will rise when lever is actuated. To lower lens, rotate grip 180°, so that white dot points downward.
This upward shift moves the image in the same direction. The adjustment is primarily used in low angle photography, to correct its resulting converging lines.
- 10
The action of the lift lever is self-braking. In cases where the friction should cease when using heavy lenses, the friction pressure may be tightened by the screws as shown in ill. 10 (right screw covered).
2. **Lateral shift** is effected by loosening the locking lever (2/ill. 9) and by pushing the lens standard to the right or left. Maximum and intermediate positions are locked by the same lever. This movement effects lateral shift of the composition to the left or to the right. The zero position is indicated by a red triangle mark and a ball catch in the foot of the standard. This lens movement is primarily used for the correction of a lateral camera position and the resulting distortion in perspective.
3. **Swivel through the vertical axis.** Turn the lever (3/ill. 9) in direction of the arrow. Now, the lens standard can be swung 15° to each side. When the lever is returned, the lens standard locks automatically into zero position. This lens adjustment moves the zone of sharp focus in the direction of the swing (refer to Linhof Technique Data Sheets, Scheimpflug rule).
4. **Tilt through the horizontal axis.** First loosen the locking screw (4), then press the knurled locking knob (5) against the lens standard. Now the lens can be tilted 15° forward and backward through its horizontal axis in the nodal point. Maximum and intermediate adjustments are locked by tightening the locking screw (4). Same results as described under paragraph 3 (refer to Linhof Technique Data Sheets).
5. **Lowering of lens standard.** Turn camera by 180° (upside down position); then loosen the knurled screw on the inside of the camera housing and detach the accessory shoe. Now another tripod socket is exposed, so that the camera can be mounted on a tripod head.

11

The Universal Camera Back

By means of the swing frame (page 3, 29), the camera back can be adjusted in all directions. Hence, amongst others, manipulation of the depth of field. Detailed instructions for the use of swings and tilts are contained in the Linhof Technique Data Sheets.

Before using the swing frame, the 4 captive locking screws (20) must be loosened. Then press inward one of the two spring tensioned locks (23) and at the same time on the pertaining guide pin (39) from the inside of the camera body (refer to 14, ill. 11). This is likewise to be done on the other side of the camera. After groundglass focusing, the swing frame can be locked in any position by tightening the four captive locking knobs (20). Caution! Before working with the multifocus rangefinder, the swing frame must be returned to zero position. Unlocking by pressing lateral knob. In addition, the detachable camera back is fitted with a revolving frame (28) for horizontal or vertical composition. It is provided with click stops in these two positions. The focusing hood snaps open after pushing the sliding button (42) against the center of the focusing hood cover. For critical focusing with the magnifier, the closed focusing hood (24) may be swung back. By pulling on the grooved tap (41), the snap button is loosened. If necessary, the focusing hood frame may be removed entirely by pressing to the right and unhooking the spring tensioned hinge.

Accessories for Super Technika V 4 x 5

1. Cold light head (003007)
2. Condensor enlarging head (003022)
3. Telephoto and special process lenses
4. Focusing bellows (002503)
5. Prontor-Ultra-selftimer (022502)
6. Spirit level (002599)
7. Optical magnifier 8 x (022513)
8. Imagon soft focus lens with 3 soft focus grids, grey filter and lens shade
9. Extreme wide angle lens
10. Focusing device for extreme wide angle lens (002555)
11. Reducing lensboard adapter
12. Special adapter for use of Lunasix Meter in connection with focusing bellows (002581)
13. Conical macro lensboard, with and without shutter
14. Macro lenses
15. Microscope adapter, with and without shutter
16. Reversal mirror attachment (002628)
17. Lens shade / filter holder
18. Screw-in lens shades
19. Slip-in filters for lens shade / filter holder
20. Reducing rings for lens shade / filter holder
21. Color separation filter attachment (003016)
22. Multifocus optical finder (001360) with reducing masks and foam rubber eyepiece (001312)
23. Frame finder with peep-sight (001316) and plexiglass masks
24. Sports finder (001315)
25. Close-up focal frame finder (002553)
26. Color Compendium, adjustable (001910)
27. Gelatine filter holder (002012)
28. Ground glass frame
29. Ground glass with format delineation (021804)
30. Ektalite field lens (002522)
31. Single film plate with film holder (021453)
32. Super Rollex holder for 10 exposures $2\frac{1}{4} \times 2\frac{3}{4}$ (001459) also available in sizes $2\frac{1}{4} \times 3\frac{1}{4}$ (001523) $2\frac{1}{4} \times 2\frac{1}{4}$ (001527) and $1\frac{3}{8} \times 2\frac{1}{4}$ (001532)
33. 70 mm cartridge (022508) and box (022511)
34. Cine Rollex holder for over 50 exposures on perforated 70 mm film (001456)
35. LINHOF double plate and cutfilm holder 4 x 5 in.
36. LINHOF Super cutfilm holder 4 x 5 in.
37. Grafmatic sheetfilm holder 4 x 5 in. (021456)
38. Police adapter for 3 exposures 4 x 6 cm (001623)
39. Rapid focusing slide
40. Reducing frame 4 x 5 / $2\frac{1}{4} \times 3\frac{1}{4}$ in. (001608) with ground glass spring back $2\frac{1}{4} \times 3\frac{1}{4}$ in. and LINHOF double plate and cutfilm holder $2\frac{1}{4} \times 3\frac{1}{4}$ in.
41. Anatomical grip, left (002549) and right (002552)
42. Outrigger plate (003754)
43. Geared focusing slide and Stereo head (003765)
44. Camera shoulder case (022419)
45. Camera Aluminium case (022403)

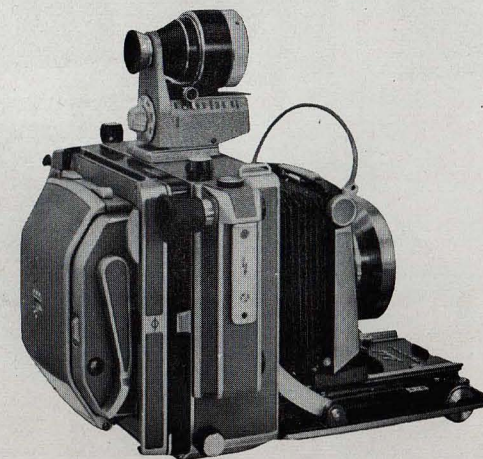
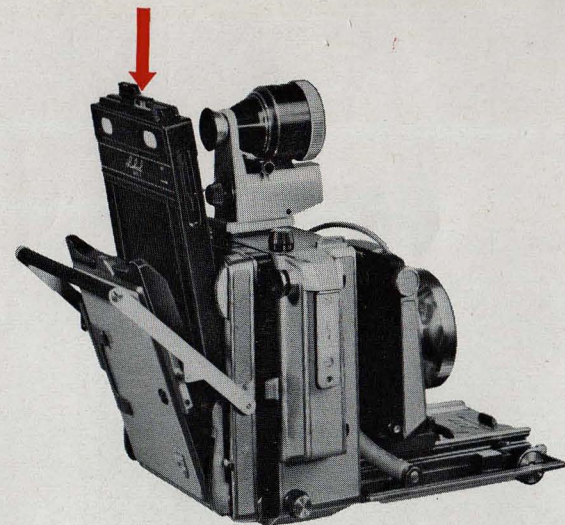

Negative Holders

While the Linhof double holders (page 18/38) are used for either plates or cutfilm, the Super cutfilm holder (page 18/39) is used exclusively with sheet film. Both types of holders are available either in 9 x 12 cm or 4 x 5 in. negative size. They are inserted between the ground glass frame and the revolving frame of the camera back until they positively engage in the groove on the small side of the back frame (see ill. above). When using the camera on a tripod, it is recommended to pull the spring-tensioned ground glass frame slightly away with the index finger, while pressing against the revolving frame with the thumb, so that the cutfilm holder may be inserted smoothly. After the exposure is made, the holder is removed from the camera by slightly pulling it backwards with the ground glass frame and slipping it out. Detailed operating instructions are enclosed with every holder. The Super Technika V 4 x 5 also can be equipped with a special back (001648) which is provided with a lift-off lever, thus greatly facilitating the use respectively insertion of double holders.

The Grafmatic sheet film holder for 6 sheet films 4 x 5 (page 18/40), is used in Linhof cameras in the same way as the double holders. To prevent light leak, the Grafmatic holder may be positively locked with the universal back by operating the two locking slides (4/36).

To attach the Super Rollex for 120 roll film (see ill. below), the Cine Rollex for 70 mm perforated film (page 18/37), the Police adapter (page 18/41) for three exposures 4 x 6 cm or the enlarging attachments (page 17, 2 and 3), the ground glass frame must be removed by pressing down its two spring-tensioned retaining arms (4/35) while sliding up the frame. The roll film holders are locked to the frame by pushing the two locking slides (page 4/36) in direction of the arrow. The dark slide of the holders which are inserted in the spring back, may be clipped to the spring clip on the outside of the focusing hood cover (page 4/34). To rotate the revolving frame for either horizontal or vertical framing, unlock lateral knob.

For use of double holders in the reducing format $2\frac{1}{4} \times 3\frac{1}{4}$ in., the standard 4 x 5 in. universal back is exchanged against a $2\frac{1}{4} \times 3\frac{1}{4}$ in. ground glass back with reducing frame (001608). To remove the universal back, turn it to a diagonal position in relation to the camera (page 3/31) and move the four locking slides (page 4/38) to the outside to disengage the revolving frame. Attaching the reducing frame with quick change back is done in the opposite manner. The reducing frame may be used either in connection with the standard ground glass back $2\frac{1}{4} \times 3\frac{1}{4}$ in. or in connection with Super respectively Cine Rollex backs of LINHOF $2\frac{1}{4} \times 3\frac{1}{4}$ in. cameras. In this case, however, focusing from ground glass back only (no coupled rangefinder focusing!).



The Immense
LINHOF Accessory
 System of the
 Super Technika V
 4 x 5 in.

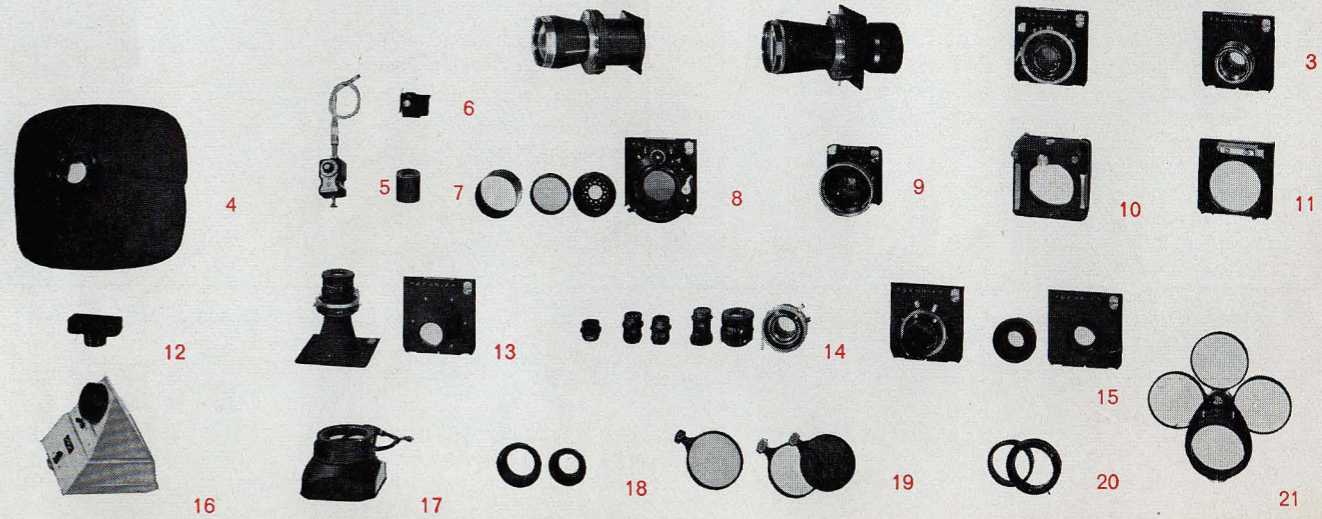
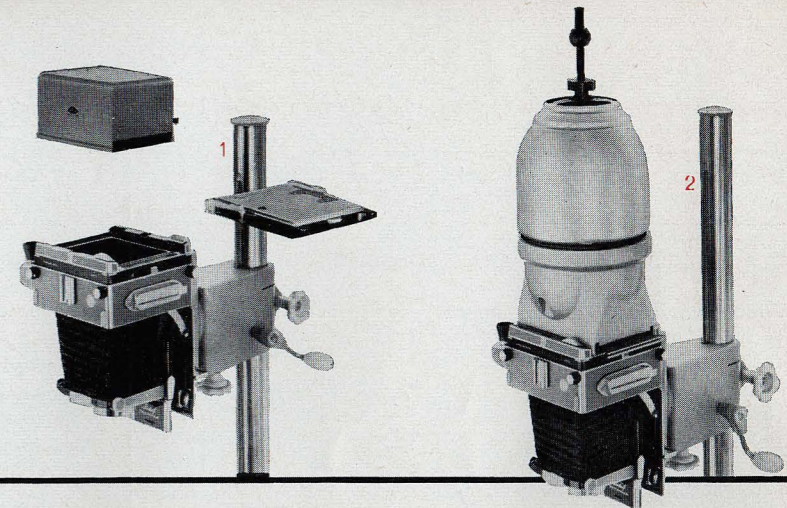

Top quality lenses of the leading German optical industry for Super Technika and Technika V 4 x 5 in. / 9 x 12 cm.

Lens name	Focal length	Speed	Shutter	Lens name	Focal length	Speed	Shutter
WIDE-ANGLE LENSES				NORMAL LENSES, LONG FOCUS			
Wide-angle Technikon*)	58 mm	1:5,6	MXVCROO 1/500	Technika Symmar	180 mm	1:5,6	MXCRI 1/400
Technika Super-Angulon	65 mm	1:5,6	OMXV 1/500	Technika Apo-Lanthar	210 mm	1:4,5	electronic 3 1/200
Technika Super-Angulon	65 mm	1:8	MXVROO 1/500	Technika Heliar	210 mm	1:4,5	electronic 3 1/200
Technika Biogon	75 mm	1:4,5	OMXV 1/500	Technika Xenar	210 mm	1:4,5	electronic 3 1/200
Technika Super-Angulon	75 mm	1:8	OMXV 1/500	Technika Symmar	210 mm	1:5,6	MXCRI 1/400
Technika Super-Angulon	90 mm	1:5,6	OMXV 1/500	Technika Heliar	240 mm	1:4,5	EX-IV/10 1/75
Technika Super-Angulon	90 mm	1:8	OMXV 1/500	Technika Xenar	240 mm	1:4,5	EX-IV/10 1/75
Technika Super-Angulon	121 mm	1:8	OMXV 1/500	Technika Symmar	240 mm	1:5,6	EX-CII/5** 1/200
NORMAL LENSES				Technika Symmar	300 mm	1:5,6	electronic 3 1/200
Technika Press-Xenar	127 mm	1:4,7	OMXV 1/500	TELE PHOTO LENSES			
Technika Planar	135 mm	1:3,5	MXCRI 1/400	Technika Tele-Arton	240 mm	1:5,6	EX-CII/5 1/200
Technika Xenotar	135 mm	1:3,5	MXCRI 1/400	Technika Sonnar	250 mm	1:5,6	MXCRI 1/400
Technika Symmar	135 mm	1:5,6	OMXV 1/500	Technika Tele-Arton	270 mm	1:5,5	MXCRI 1/400
Technika Xenotar	150 mm	1:2,8	EX-CII/5** 1/200	Technika Rotelar	270 mm	1:5,6	MXCRI 1/400
Technika Apo-Lanthar	150 mm	1:4,5	MXCRI 1/400	Technika Telomar	360 mm	1:5,5	electronic 3 1/200
Technika Symmar	150 mm	1:5,6	MXCRI 1/400	Technika Tele-Arton	360 mm	1:5,5	electronic 3 1/200
Technika Heliar	150 mm	1:4,5	MXCRI 1/400				
Technika Xenar	150 mm	1:4,5	MXCRI 1/400				

*) Covers only a negative format with 145 mm diagonal

**) Also available in electronic 3 Shutter

For further lenses refer to the price list.

Linhof

NIKOLAUS KARPFF KG. · PRÄZISIONS-KAMERA-WERK · MÜNCHEN 25

Telefon: (08 11) 73 30 81 · Telex: 523312 Ilnka d