

MADE IN GERMANY



Linhof

LINHOF M 679^{CS}

E

1. THE DESIGN PRINCIPLE	5	3. LENSES AND SHUTTERS	30
1.1. THE SYSTEM OF THE M 679cs - ACCESSORIES	6	3.1. LENS SELECTION	31
1.2. ORDERING INFORMATION	7	3.2. IMAGE CIRCLE	32
1.3. TECHNICAL DATA LINHOF M 679cs	8	3.3. LENSBOARDS	33
		3.4. SHUTTERS	34
2. CAMERA DESIGN DETAILS AND ACCESSORIES	9	3.5. DIGITAL LENSES	35
2.1. FEATURES AND CONTROLS	10		
2.2. THE OPTICAL BENCH	12	4. CAMERA ADJUSTMENTS	36
2.3. THE INTEGRATED LEVELLING BENCHHOLDER	13	4.1. VERTICAL AND LATERAL SHIFT (DIRECT DISPLACEMENT)	37
2.4. BELLOWS AND BELLOWS CHANGE	14	4.2. INDIRECT PARALLEL DISPLACEMENTS	38
2.5. THE LENS STANDARD	15	4.3. VERTICAL PARALLEL SHIFTS (INDIRECT)	39
2.6. LENS CHANGE	15	4.4. HORIZONTAL PARALLEL SHIFTS (INDIRECT)	41
2.7. COMPENDIUMS	15	4.5. COMBINED PARALLEL SHIFTS	42
2.8. REAR STANDARD	17	4.6. SCHEIMPFLUG ADJUSTMENTS	43
2.9. M 679cs GROUNDGLASS BACK	17	4.7. DEPTH-OF-FIELD WEDGE	46
2.10. GROUNDGLASSES	17	4.8. SUMMARY	47
2.11. FOCUSING AIDS	18	4.9. DEPTH-OF-FIELD AND DEPTH-OF-FIELD OPTIMIZER	48
2.12. ADAPTERS FOR ROLLFILM AND DIGITAL IMAGING	20	4.10. WHAT ABOUT YAWING?	50
2.13. ADAPTERS FOR DIGITAL BACKS	22	4.11. VIEW CAMERA MOVEMENTS MADE SIMPLE	51
2.14. RAPID CHANGE ADAPTER SLIDE	23		
2.15. UNIVERSAL ADAPTER SYSTEM	24		
2.16. M 679 COMPONENTS TO USE WITH 4x5 CAMERAS	26		
2.17. STAND ALONE POLAROID BACK	27		
2.18. THE SYSTAINER TRANSPORTATION LINHOF M 679cs	28		
2.19. TRIPODS AND TRIPOD HEADS	29		

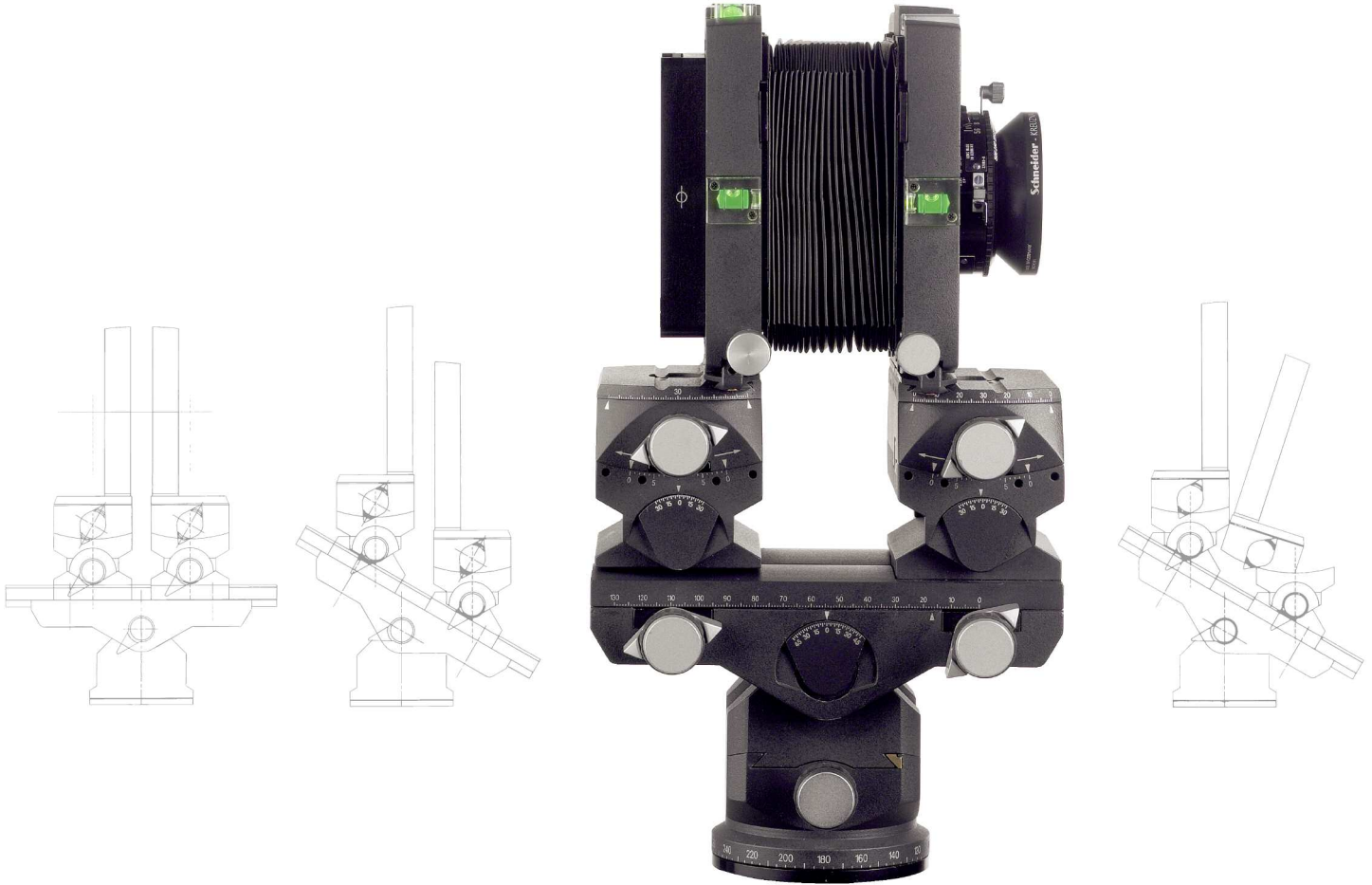

1. THE DESIGN PRINCIPLE

The Linhof M 679cs is a modular view camera for the formats 6x6 cm /2 1/4 x 2 1/4 in. up to 6x9 cm/2 1¼ x 3 1¼ in.

A special adapter system permits the use with commonly used medium format systems by utilizing existing magazines. The same adapters for the various medium format camera systems permit the use of all existing scan and chip backs. Therefore, the Linhof M 679cs is the ideal tool for all photographers who:

- a. start working with an adjustable camera system by utilizing their own medium format equipment,
- b. need a compact camera system for digital imaging as well as analogue professional photography on classic rollfilm.

Ease of use, almost unlimited flexibility, and a complete range of accessories make the M 679 the ideal camera.

The following features mean the 679 is capable of being set up, adjusted, and used with the greatest of ease. The base of the camera is an optical bench with two parallel rails from 53 (35) -326 mm. This means lenses from 24 - 240 mm can be used without extension rails.

The M 679cs has been ergonomically designed with precision micro drives and positive locks for exact, fast and errorfree use.

All movements are made by rotating control knobs. This procedure guarantees effortless and precise adjustments to be made and easily seen on the viewing screen.

The method of indirect displacement is used on the M 679cs which speeds up the work of any photographer. The required result either on

film or on chip is faster and more precisely achieved than with the conventional method of direct displacement. Micro drives serve for fine adjustments of lateral and horizontal shifts at the lens standard and the rear standard.

The integrated panorama benchholder with stepless lateral levelling of 10° not only serves as an additional tilt or ballhead but also allows precise repetition of a shot because of its calibrated scale.

Front and rear standards are steplessly moved in tilt segments. Thereby giving permanent yawfree operation, and avoiding converging lines by exact alignment of the vertical plane, for example, in architectural photography. The basic principles of large format photography are easily applied on the M 679cs due to the accuracy of all measurement scales.

The front and rear standard can be turned by +/- 30° around the vertical axis and by 36° and 24° respectively around the horizontal axis.

This feature enables the image circle of the lens to be fully exploited. This is an optimum in utilization of the image angle and the image circle of the lenses. The lenses mounted on lensboards are freely accessible from 3 sides and can be used in all known mechanical and electronic shutters.

The groundglass back has interchangeable groundglasses for different formats. A sliding Fresnel screen and a viewer allow the uncomplicated viewing of a bright and undistorted groundglass image even if the camera is extremely displaced.

A huge range of accessories permit convenient image control and fast operation by using the Linhof Rapid Change Adapter Slides.

1.1. THE SYSTEM OF THE M 679cs - ACCESSORIES

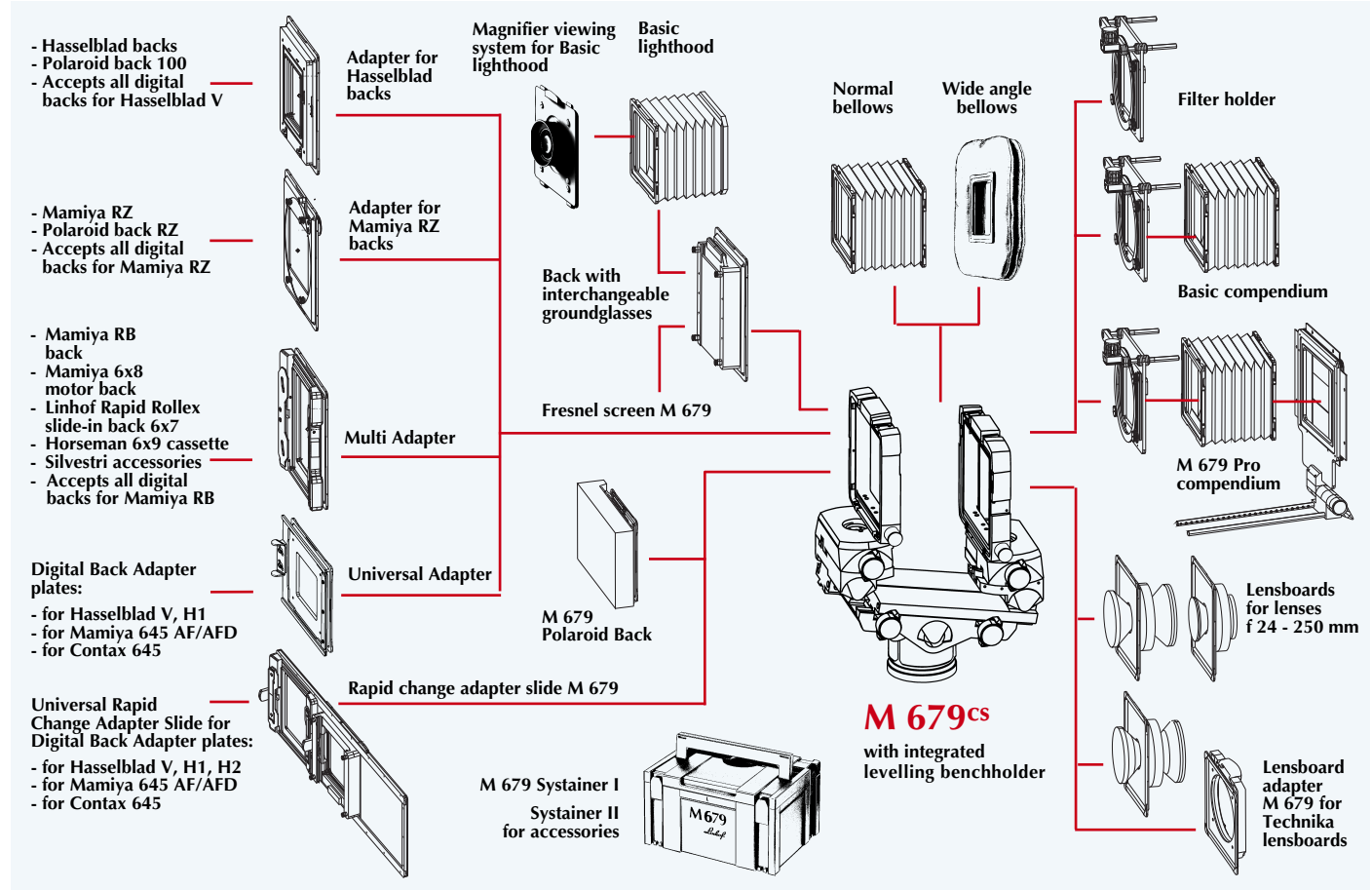

1.2. ORDERING INFORMATION

LINHOFF M 679cs incl. bellows, front and rear standard, with integrated benchholder with stepless lateral levelling, without lens and back	000117	Universal Rapid Change Adapter Slide M 679 - 37x37 / 37x71 and 37x49 / 49x71	002766-S
M 679cs Groundglass back	001698-S	Adapter plate for Hasselblad V	001700
Groundglass scoring 3x3	021833-S	Adapter plate for Hasselblad H 1, H2	001701
Groundglass scoring 6x6	021834-S	Adapter plate for Mamiya 645 AF / AFD	001702
Groundglass scoring 6x7	021835-S	Adapter plate for Contax 645	001703
Groundglass scoring 6x8	021836-S	Flexible shafts for M 679cs shift (2 pcs.)	002769
Groundglass scoring 6x9	021842-S	Wide Angle Bellows M 679	002754
Groundglass scoring 24x36 / 36x63	021837-S	Normal Bellows M 679 (spare)	002753
Groundglass scoring 37x37 / 37x71	021838-S	Basic Compendium Lensshade M 679 incl. Filter Holder	001939
Groundglass scoring 37x49 / 49x71	021840-S	Pro Compendium M 679 incl. Filter Holder and Vignetting Mask Holder	001940
Groundglass scoring 33x44	021841-S	Filter Holder M 679 M105x1 and 10x10 cm	001941
Groundglass scoring 72x88 (Anagramm)	021839	Vignetting Mask Holder M 679	001942
Fresnel Screen M 679	002523	Flat Lensboard M 679 size 0	001160
Acute Groundglass for M679cs, 37x37 / 37x49	021843-S	Flat Lensboard M 679 size 1	001161
Acute Groundglass for M679cs, 33x44	021844-S	Flat Lensboard M 679 size 3	001173
Format dial 6x7 M 679cs for format 6x6 - 6x8 (included in camera price M 679cs)	003905	Recessed Lensboard M 679, size 0	001163
Format dial 3x3 M 679cs	003906	Recessed Lensboard M 679, size 1 / Rollei Shutter.	001164
Format dial 6x9 M 679cs	003907	Double Recessed Lensboard M 679 size 0	001176
Basic Lighthood M 679	002763-S	Double Rec. Lensboard M 679, size 1 / Rollei Shutter	001174
Magnifier Viewing System 8x8 for Basic Lighthood	002757	3x Recessed Lensboard M 679, size 0	001175
M 679 Adapter for Hasselblad V backs	001694	3x Recessed Lensboard M 679, size 1 / Rollei Shutter	001177
M 679 Adapter for Mamiya RZ backs	001696	4x Recessed Lensboard M 679, size 0 for	
Adapter for Anagramm Scanning back	064924	Apo-Digital XL 5,6/35, Copal 0	001178
Multi Adapter for Mamiya RB, Mamiya 6x8 motor cassette,		Lensboard Adapter M 679 / Technika 45 lensboard	001100
Linhof Rapid Rollex 6x7, Horseman 6x7/6x8/6x9	001695	Adapter Linhof Kardan for M 679	001101
Universal Adapter for camera adapter plates	001697	Adapter Sinar / Horseman for M 679	001102
Groundglass Silvestri 6x9	S-24011	Adapter Cambo for M 679	001103
Focusing Bellows with Magnifier / Silvestri 6x9	S-25010	Adapter plate for Hasselblad Finder	001104
Right Angle Attachment / Silvestri 6x9	S-25030	Adapter plate for Arca Swiss Bino Tube on M 679	001105-S
Polaroid Back M 679	001692	Systainer M 679	022491
Universal Rapid Change Adapter Slide		Systainer II M 679 for Accessories	022492
M 679 24x36 / 36x63	002765-S		

1.3. TECHNICAL DATA LINHOF M 679cs

Overall camera dimensions in basic position with integrated panorama benchholder	Length: 170 mm, width: 153 mm, height: 294 mm 6.7 x 6.0 x 11.6"
Weight	Approximately 4.500 g with integrated benchholder
Maximum camera extension of non-adjusted camera in normal position (lens to film plane)	326 mm / 12.8"
Minimum camera extension with wide-angle bellows (lens to film plane)	53 mm with recessed lensboard 40 mm with double recessed lensboard 35 mm with 4x recessed lensboard
Indirect parallel adjustment (up/down), maximum extension and tilting angle of the optical bench of 30°	168 mm / 6.6"
Indirect vertical parallel shift (up/down) minimum extension and tilting angle of optical bench 30°	38 mm / 1.5" (limitations with focal lengths of less than 47 mm)
Indirect horizontal parallel shift (lateral shift left/right)	168 mm / 6.6" maximum extension
Indirect horizontal parallel shift (lateral shift left/right) minimum extension	38 mm / 1.5" (limitations with focal lengths of less than 47 mm)
Direct cropping correction lens standard	Lateral shift right - left 20 mm, Vertical shift 20 mm
Direct cropping correction rear standard	Lateral shift right - left 20 mm, Vertical shift 20 mm
Panorama benchholder	Tilting front 45°, rear tilting 45° Panorama rotation 360°, lateral levelling 10° each side
Tilts of front and rear standard to optical bench	30° each front and rear
Front standard / Rear standard	Vertical axis swing +/- 30° Tilting around the horizontal axis front 18° / 12° Tilting around the horizontal axis rear 12° / 18°

2. CAMERA DESIGN DETAILS AND ACCESSORIES



The Linhof M 679cs is a system camera with an utmost flexibility of the individual system components.

The basic idea is an optimum operation ease. Therefore the system is continuously updated to the current needs.

The basic lighthouse serves as a light shield permitting viewing in brighter areas. The magnifier viewing adapter 8x8 can be linked to the basic lighthouse.

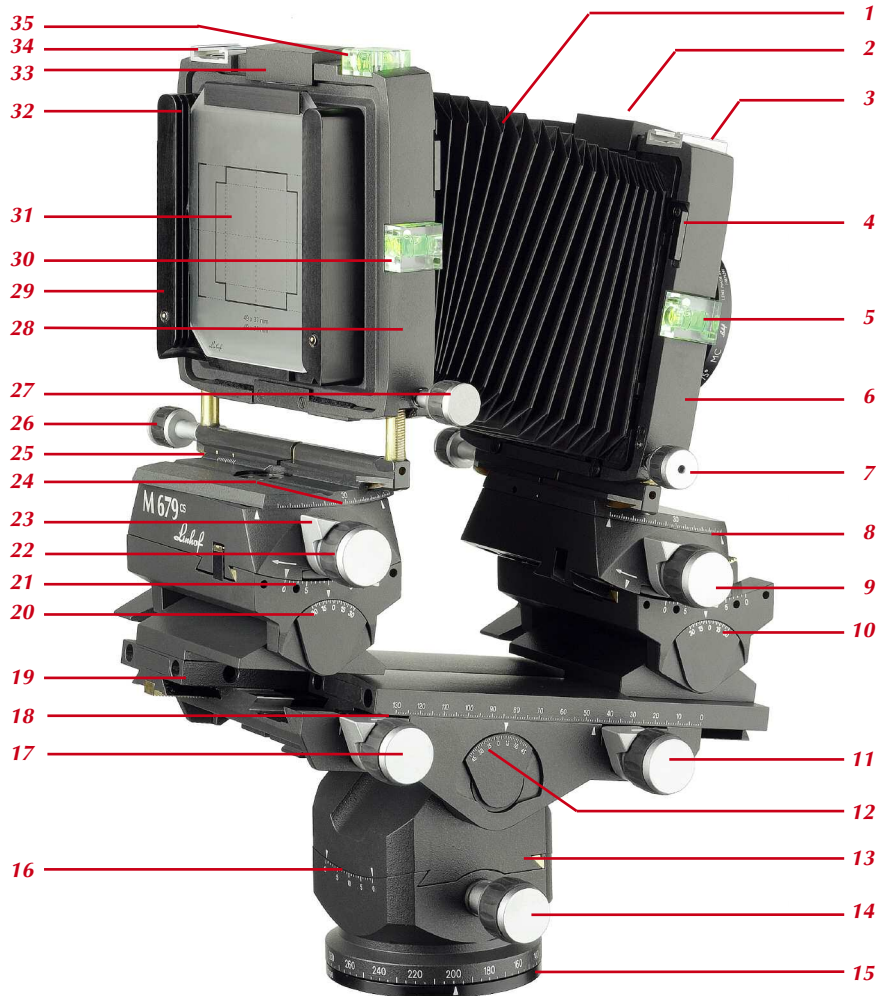

2.1. FEATURES AND CONTROLS

- 1 Normal bellows
- 2 Unlocking of lensboard
- 3 Accessory shoe for filter holder, compendium etc.
- 4 Lever for change of bellows
- 5 Spirit level to control adjustment of lens standard to vertical
- 6 Lens standard
- 7 Self-aligning micro drives for horizontal shift of the lens standard
- 8 Scale for swinging the lens standard around the vertical axis
- 9 Rack and pinion drive for tilting of the lens standard around the horizontal axis
- 10 Scale for basic tilting angle of the lens standards
- 11 Turning knob for basic extension and for close up focusing
- 12 Scale for tilting angle of the optical bench
- 13 Integrated panorama benchholder with stepless self-aligning lateral levelling and panorama rotation
- 14 Rack and pinion drive for lateral levelling
- 15 Scale for panorama rotation of the benchholder
- 16 Scale for lateral levelling
- 17 Focusing knob
- 18 Scale for focusing and further extension
- 19 Rails of the optical bench
- 20 Scale for basic tilting angle of the rear standard
- 21 Scale for tilting angle of the rear standard
- 22 Rack and pinion drive for tilting of the rear standard
- 23 Integrated locking lever at the turning knobs
- 24 Scale for swinging of the rear standard
- 25 Scale for lateral shift (cropping correction)

- 26 Rack and pinion drive for lateral shift of the rear standard
- 27 Rack and pinion drive for vertical shift of the rear standard
- 28 Rear standard
- 29 Groundglass back for interchangeable groundglasses and focusing aids
- 30 Spirit level for adjusting the rear standard to vertical for avoiding converging lines
- 31 Interchangeable format groundglasses
- 32 3 grooves for easy change of groundglasses, Fresnel screens and basic lighthoods
- 33 Unlocking device for groundglass back, adapters and Rapid Change Adapter Slides
- 34 Accessory shoe
- 35 Spirit level for horizontal adjustment
- 36 Rack and pinion drive for swinging the rear standard around the vertical axis
- 37 Scale for tilting of the lens standard around the horizontal axis
- 38 Basis locking of the rear standard
- 39 Scale for focusing and increased extension
- 40 Depth-of-field optimizer
- 41 Locking lever for panorama benchholder
- 42 Locking knob of panorama rotation
- 43 2 holes for compendium guide rails
- 44 Basis locking of the lens standard
- 45 Scale for tilting of the lens standard around the horizontal axis
- 46 Rack and pinion drive for swinging of the lens standard around the vertical axis
- 47 Scale for swinging of the lens standard
- 48 Rack and pinion drive for lateral shift
- 49 Scale for lateral shift of the lens standard
- 50 Interchangeable lens
- 51 Lensboard M 679

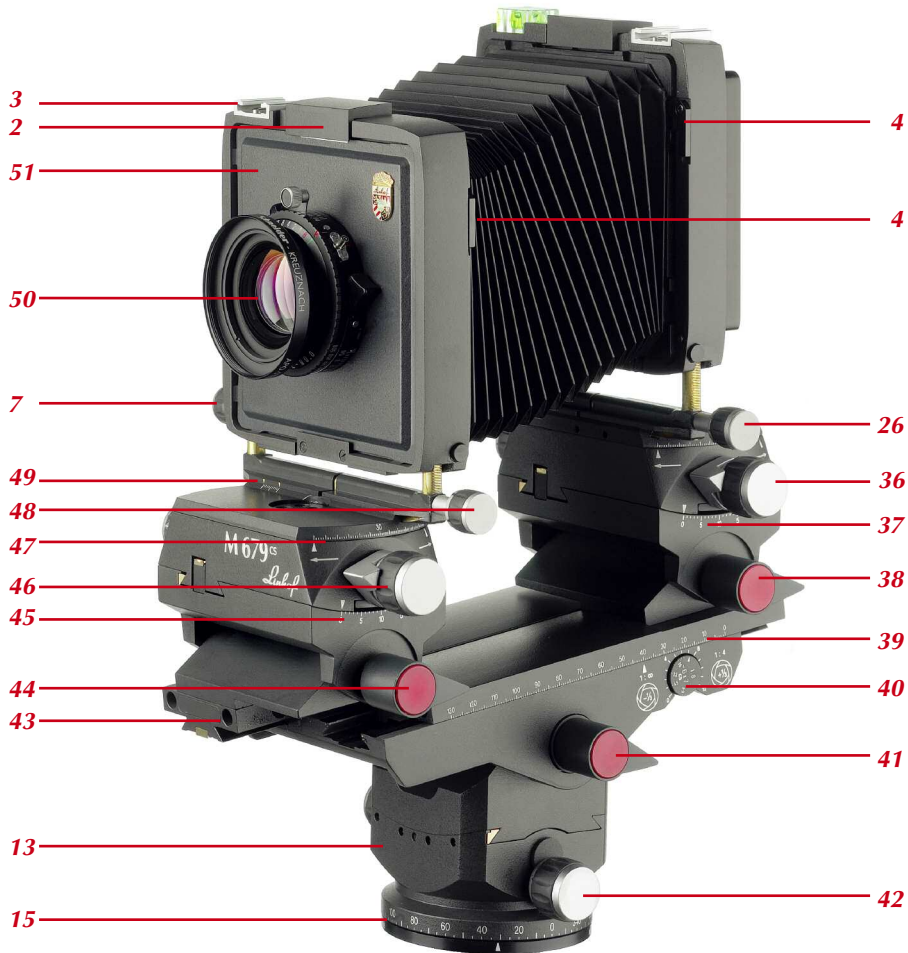

2.2. THE OPTICAL BENCH

The base of the camera is an optical bench with two parallel guided rails. Although extremely compact, the camera offers sufficient extension up to maximum 326 mm for long focal lengths – as well as for close ups. This means starting with wide-angle of 24 mm to tele 240 mm. The focal length is coupled with the taking format: 240 mm with 6x7 cm format corresponds to 450 mm with 4x5 in. format. The telescoping extension of the optical bench can be reached with the front and rear standard. For better balancing the extension should always be made with both standards. Focusing is effected with the same elements also realizing the extension changes: the camera can be focused with the front standard as well as with the rear standard. The rear standard has got the depth-of-field optimizer (40) guaranteeing the calculation of the exact focus point. Turning knob (11) und focusing knob (17) have integrated locking levers (23), which should always be applied after any change of the extension or change of focus.

Both standards are linked to base tilt elements serving to adjust the camera to vertical for vertical parallel displacements (38, 44).



Camera shown with maximum extension.

Camera shown in compact position.

2.3. INTEGRATED LEVELLING BENCHHOLDER

Any studio camera requires a pan/tilt head or ballhead. The Linhof M 679cs is supplied with an already integrated panorama benchholder offering many advantages: various adjustments or extreme displacement make it necessary to know the exact angle of the tilting degree.

Therefore, the integrated benchholder of the M 679cs has a precise angle scale. The maximum tilting to either side is 45°, the panorama rotation is 360°.

All displacements start with the benchholder: unlock the holder (41), set the camera to the subject and lock. The built-in zero click and a retention spring facilitate the operation.

The integrated panorama bench holder features a stepless lateral levelling of 10° each side by means of self-aligning micro drives. Practically all photographic problems can now be solved without the need of an additional tripod head.



Attention please:
Locking after each displacements with the red coloured levers is strongly advised (38, 41, 44).

The integrated panorama benchholder with 3/8" retaining socket.

2.4. BELLOWS AND BELLOWS CHANGE

Lenses of different focal lengths require different camera extensions. The normal bellows can be exchanged very quickly with the wide-angle bellows (and vice versa): unlock each lever right and left at the inner lens and rear standard (4).

The normal bellows is very flexible but at the same time stable enough to allow extreme displacements.

The wide angle bellows (Code 002754) of the Linhof M 679cs is double-folded permitting extreme extensions. Therefore, the extension range is wide enough to avoid changing the bellows unnecessarily.

The wide angle bellows is used for focal length of 24 – 90 mm, the normal bellows is used for lenses with focal lengths of 90 to 240 mm.



*M 679cs with
wide angle bellows,
35 mm lens and
lens rise.*



*Linhof M 679cs with
normal bellows*

2.5. THE LENS STANDARD

By swinging around the vertical and horizontal axis lenses over 90 mm focal length are turned around the principle point in such a way that the framing chosen before is hardly changed. The lenses mounted on lensboards are freely accessible from 3 sides utilizing all known mechanical and electronic shutters. Linhof supplies lenses complete with shutter mounted on the appropriate lensboard. Informations for lens selection, lensboards and shutters please see chapter 3.

2.6. LENS CHANGE

Lenses/lensboards are easily changed by a click clack mechanism: just unlock a lever (2) and the lensboard is free. Insert the lensboard by simply pressing into the snap-on device. (We recommend a hand counter pressure at the standard.) The lensboard is square, the lens is exactly centered in the board which can therefore be inserted in either way right and left. Cables of digital shutters can therefore be used from any side.

2.7. COMPENDIUMS

For obtaining brilliant pictures a compendium is a must for adjustable cameras. Lenses with the huge image angle of view of applied photography require an appropriate lensshade. Such a lensshade should also offer sufficient adjustment facilities. A compendium is an indispensable accessory as it ensures best possible exposures of flare-free definition, contrast and colour saturation. For the M 679cs two compendiums with integrated filterholder are offered.

The **FILTER HOLDER M 679** (001941) can also be ordered separately. This accessory is adapted to the accessory shoe accepting gelatine filter and up to 2 acrylic glass filter 10x10 cm as well as screw-in filter M 105 x 1. For changing lenses the basic compendium can remain at the camera: With the counter part of the accessory shoe the compendium can be moved aside.



Filter holder on the M 679



The **BASIC COMPENDIUM** (001939, incl. filter holder) consists of a small flexible self-supporting bellows and is supplied complete with filterholder. The basic compendium has to be adapted to the filterholder. The self-supporting bellows can also be utilized as basic lighthood. With the counter part of the accessory shoe the compendium can be moved aside after unlocking the knob.



The **M 679 PROFESSIONAL COMPENDIUM** (001940) consists of the filterholder, a M 679 normal bellows and the vignetting mask holder and will be supplied as a complete unit. This compendium is centered automatically. It is inserted into the optical bench and is therefore always in the optical axis. It is sufficient to align the compendium standard parallel to the rear standard using the red locking lever.

The filterholder of the Pro Compendium is inserted in the accessory shoe of the camera body. For special effects, double exposures, section framings and as a protection against unwanted side light there are vignetting blinds available.

The M 679 Professional Compendium with intelligent adaptation at the optical bench

2.8. REAR STANDARD

The maximum usable format is 6x9 cm. Special adapters for each system are the link for compatibility with the commonly used medium format systems by utilizing existing magazines (analogue and digital). Swinging is principally made around the vertical and horizontal axis in the format centre which means that the image center once focused sharp will remain sharp at any displacement.

All backs are freely accessible from the three sides. The easily detachable groundglass back accepts the groundglasses as well as various viewing aids.

2.9. GROUNDGLASS BACK

The detachable groundglass back accepts various groundglasses and viewing aids.

VERTICAL OR HORIZONTAL FORMAT

By simple fingertip pressure the groundglass back with inserted groundglass can be unlocked and be taken off for change of vertical to horizontal format, sometimes even with attached viewing aid.



The M 679cs groundglass back (001698-S) has 3 grooves for inserting the interchangeable format groundglasses, the Fresnel screen as well as the viewing aids.

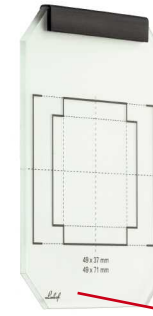

Interchangeable format groundglasses with scoring for stitching facilities in combination with rapid change adapter slide.

The groundglasses "S" matching the groundglass back 001698-S have the imprinted logo in the bottom left corner for better identification.

2.10. GROUNDGLASSES

Several groundglasses according to the required formats are offered with grids of 3x3 cm up to 6x9 cm. The groundglass is changed with the aid of a small handgrip, therefore no screws, no

clamps. The groundglass is inserted into the first groove at the camera back. The only exception is the the Silvestri 6x9 groundglass used as an attachment to the multi adapter.

The corresponding interchangeable format groundglasses can be changed by using the handgrip.

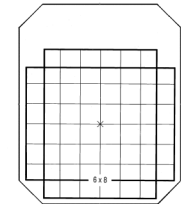
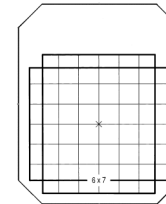
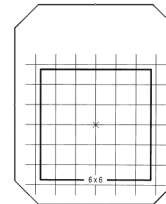
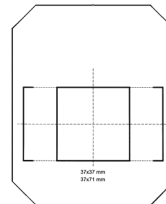
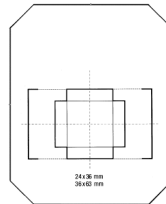

„ACUTE“ GROUNDGLASS (021843-S)

The „Acute“ groundglass is known to be super bright allowing easier composition and focusing even with extremely short focal lengths. To use the original „Acute“ groundglass with the Linhof M 679 system we have framed this glass inside a metal plate matching the same outer dimensions as the original Linhof groundglass. An easy and quick exchange from the „Acute“ to the Linhof groundglass is possible at any time.



There are two formats available for the Acute groundglass M 679cs: Code No. 021843-S for format 37x37 / 37x49 mm and Code No. 021844-S for format 33x44 mm.

2.11. FOCUSING AIDS

By viewing via groundglass the image control is facilitated by various system accessories.

THE M 679 FRESNEL SCREEN

For increasing the brightness of the image corners when using short focal lengths so-called Fresnel screens are used.

With the Linhof M 679 the optical centre of the Fresnel screen is offset from the centre of the screen. In addition it can be moved up and down which means that the brightest part can be positioned on the darker portions of the focusing screen. Because of this a right angle viewfinder can be used without image vignetting. By turning the complete groundglass back by 90° also the darker parts of the lateral shift can be compensated.

The Fresnel screen is placed over the ground-

The Acute groundglass is slotted into the first groove of the groundglass back M 679. The rear side of the metal plate accepts all Hasselblad finder systems.

glass with the grooved side towards the lens. It is slotted into the 2nd groove of the groundglass back permitting easy moving up and down.



The Fresnel screen can be moved up and down. The illustration shows the use of the Fresnel screen at lens rise. By fully utilizing the special design of the screen we have not only moved it up but also inserted the screen with the offset center in top position.



THE BASIC LIGHTHOOD (002763-S) serves as light shield permitting viewing in brighter areas. The basic lighthood consists of a self-supporting flexible bellows identical with the bellows of the basic compendium. The basic lighthood is slotted behind groundglass and Fresnel screen in to the third groove of the groundglass back.



THE MAGNIFIER VIEWING ADAPTER 8x8 (002757) to be attached to the basic lighthood permitting viewing of the total groundglass area.

FURTHER VIEWING AIDS

The following accessories are furthermore available:

Adapter plate for Arca Swiss Bino Tube

(001105-S): This item is slotted into the 3rd groove of the groundglass back accepting the Arca Swiss Bino Tube, enabling a binocular upright image control.

Adapter plate for Hasselblad Finder (001104):

This adapter permits the use of the Hasselblad Hasselblad reflex finder RMFX allowing to control an 6x6 image section (see illustration opposite page).

This Hasselblad finder is especially recommended in combination with the Acute groundglass M 679cs.

2.12. ADAPTERS FOR ROLLFILM AND DIGITAL IMAGING

The Linhof M 679cs is a universal tool by using various medium format magazines for classical rollfilm photography as well as for digital backs for electronic imaging. Special adapters for each system are the link.



Medium format rollfilm backs which can be adapted at the M 679cs.

THE HASSELBLAD V ADAPTER

Accepts the complete Hasselblad V back technique such as rollfilm magazines, Polaroid magazine 100, and all backs adaptable to Hasselblad V.

Operation when using rollfilm magazines:

Place rollfilm in the supply chamber and advance the film with the crank of the magazine to the first frame. After exposure of the first frame it is necessary to actuate the slide at the adapter four times in order to release the locking of the transport crank (1). Advance film now with the crank until the counter shows frame number 2. Stop advancing when the white index mark is visible in the small window. For every further exposure advance the film normally with the crank. For correct frame distances please observe that you can definitely see the white index mark with every exposure. When using the Hasselblad Polaroid back it is necessary to move the metal lever situated at the left lower side of the Hasselblad adapter upwards (2). This lever (3) serves for detaching the Polaroid back from the adapter by pressing it in the right hand direction. Once used, the lever can be returned to its original position.



3 For detaching the Polaroid back from the adapter press in the right hand direction.

2 When using the Hasselblad Polaroid back it is necessary to move the metal lever upwards (2).





THE MAMIYA ADAPTER

To be used for RZ magazine Pro 2, Polaroid cassette RZ and all digital backs adapted for the Mamiya RZ.

Operation when using rollfilm cassettes:

Transport film to the first frame with the winding knob on the magazine. After each exposure press lever to the right (lever situated top right at the adapter) to release for winding the next frame.



THE MULTI ADAPTER

Accepts the Mamiya RB magazine Pro SD, the Mamiya 6x8 motor cassette, Horseman back 6x7/6x8/6x9, the Linhof Rapid Rollex slide-in cassette 6x7 as well as Silvestri system accessories. Cassettes, accessories and backs are held by a slide locking mechanism.

The Multi Adapter accepts all digital backs adapted to Mamiya RB.



Multi adapter with Silvestri special groundglass 6x9



Fits on the Multi adapter: Silvestri focusing hood with magnifier.



Fits on the Multi adapter: Silvestri right angle attachment.



2.13. ADAPTERS FOR DIGITAL BACKS

The Linhof M 679cs offers the freedom to use either the digital back of your choice or rollfilm backs without complicated modifications. An intelligent adapter system permits the operation of all commonly used digital backs and medium format rollfilm backs for 6x6 to 6x9 cm. Tailor-made accessories are available for any creative idea including the precisely milled quality adapters.

You can choose adapters for digital backs or rollfilm backs. For example: Hasselblad Adapter V (001694), Mamiya RZ Adapter (001696) or Multi-Adapter for Mamiya RB, Linhof Rapid Rollex, Horseman, Silvestri acces-

sories (001695). Or you choose the Universal Adapter (001697) in combination with the corresponding camera adapter plate for your digital back. The perfect workflow with groundglass viewing permits the Rapid Change Adapter Slide (02765-S or 02766-S) for quick change of image composition to picture taking. You have the option to enlarge the image area by stitching.

The Linhof M 679cs – the ideal platform for digital professional photography.



2.14. RAPID CHANGE ADAPTER SLIDE

The Linhof Rapid Change Adapter Slide permits continuous work flow by rapidly changing the complete image composition to picture taking without taking off or attaching backs. At the same time the chip of the digital back is protected against dust and mechanical damage. The Universal Rapid Change Adapter Slide is attached to the rear standard the same way as the groundglass back. The slide permits stitching: 2 or 3 shots enlarge the image size of the digital back. Camera adapter plates suiting the different cameras in the market firmly connect the digital back with the slide.

Presently 2 different Universal slides are offered: One for chip formats 24x36 mm and one for 37x37 mm plus 37x39 mm. The corresponding groundlasses show the formats of the chip sizes with stitching.

As the Rapid Change Adapter Slides (002765-S and 002766-S) are supplied with integrated groundglass back (001698-S) all viewing aids can be attached.

FLEXIBLE SHAFTS (002769) permit smooth vertical or horizontal shifting with adapted Rapid Change Adapter Slide.

Flexible shafts (code 002769) permit smooth vertical or horizontal shifting with adapted Rapid Change Adapter Slide.

Rapid Change Adapter Slide with digital back

2.15. UNIVERSAL ADAPTER SYSTEM



Digital backs adapted to different medium format cameras can be combined with digital backs for use with the ingenious view camera system Linhof M 679cs.

THE LINHOF M 679 UNIVERSAL ADAPTER

SYSTEM offers even more compatibility to digital backs: Digital backs adapted to different medium format cameras can be combined with digital backs for use with the ingenious view camera system Linhof M 679cs.

VIEWING VIA MONITOR

A combination of precision adapters is the link of the Linhof M 679cs with the digital back. When controlling via monitor the new Universal Adapter code 001697 will be required. Now the photographer can work with digital backs of either Hasselblad V, H1, H2, Mamiya 645 AF/AFD or Contax 645 using if required in parallel the Linhof M 679 as an adjustable view camera for applied photography.

VIEWING VIA GROUNDGLASS

For digital photography with professional displacements via groundglass control we recommend the Linhof Rapid Change Adapter Slide which is now also offered as Universal Adapter Slide with additional Adapter plates. This slide

permits the quick and easy move from composition to exposure.

The digital back and the Universal Adapter Slide with corresponding Adapter plate are perfectly linked by a safety locking system with either Hasselblad H1 and H2, Hasselblad V, Mamiya 645 AF/AFD or Contax 645.

CHIP SIZE 24x36 mm

We offer 2 alternatives for different chip sizes relating to the exposure area: For sensor size 24x36 mm you will require our Universal Adapter Slide code 002765-S with corresponding groundglass code 021837-S. Thanks to integrated stops (white marks) stitching is made possible: 3 exposures will enlarge the exposure area to 36x63 mm.

CHIP SIZE 37x37 mm

For larger chip formats of 37x37 mm and 37x49 mm the Universal Adapter Slide code 002766-S is available. Chip format 37x37 mm with groundglass code 021840-S can be enlarged by stitching (2 exposures) reaching a total format of 37x71 mm.

CHIP SIZE 37x49 mm

Also here the Universal Adapter Slide code 002766-S is needed in combination with groundglass code 021840-S. Exposure area can be enlarged by stitching. By two exposures the area will reach 49x71 mm.

ACUTE GROUNDGLASS

The M 679cs Acute groundglass can also be used with the Universal Rapid Change Adapter Slide. Scorings are for formats 37x37/ 37x49 (021843-S) and 33x44 (021844-S).

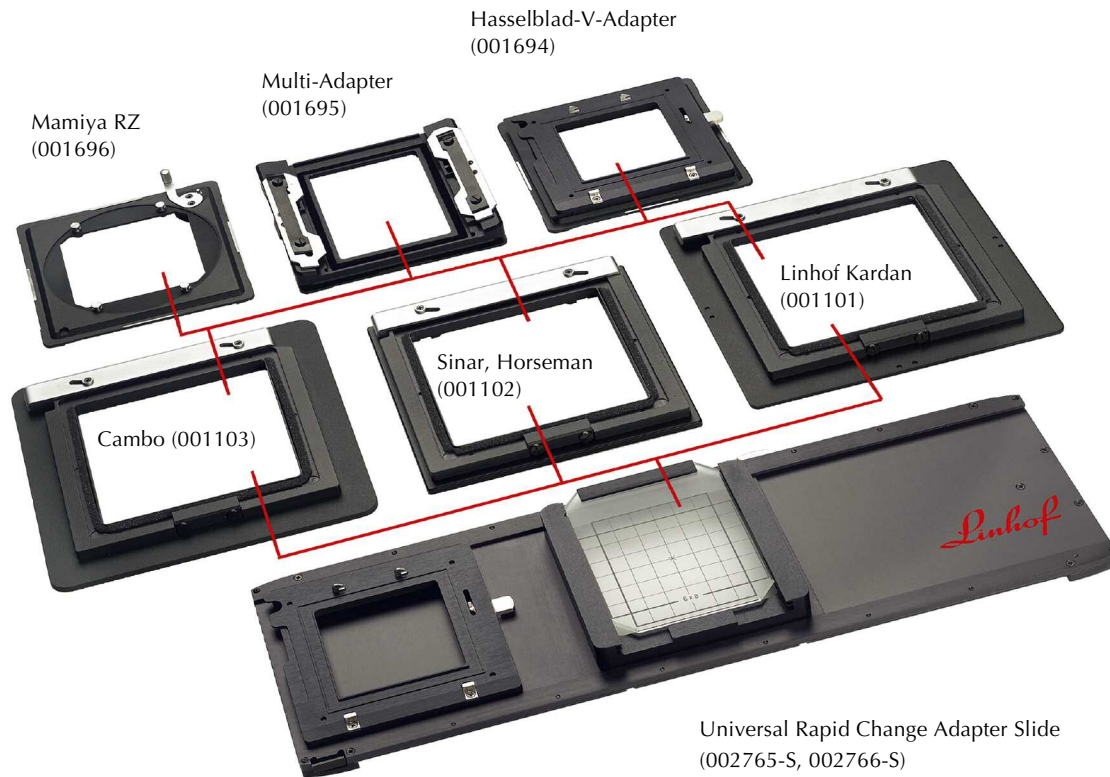

2.16. M 679 COMPONENTS TO USE WITH 4x5 CAMERAS

The Universal Adapter (001697) as well as both Universal Rapid Change Adapter Slides (002765-S and 002766-S) can be attached to 9x12 / 4x5 view cameras such as Linhof Kardan, Sinar, Horseman and Cambo. The Linhof Adapters (001101, 001102 and 001103) for different Linhof and non-Linhof cameras offer compatibility to the Linhof M 679. Lenses mounted on M 679 lensboards can be attached to these adapters.

Adapter for 4x5" cameras for using M 679 components

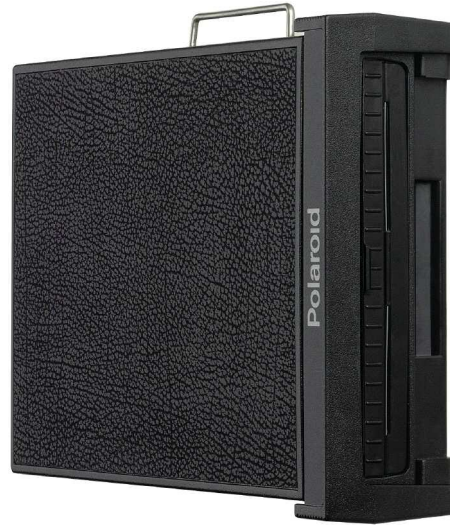

2.17. STAND ALONE POLAROID BACK

This Polaroid back especially developed for the Linhof M 679 utilizes the 600 range of Polaroid films. This Polaroid back is used independently from the individual format. Instant photography over the entire area for quick image composing and exposure control.

Polaroid back for Linhof M 679

2.18. THE SYSTAINER TRANSPORTATION LINHOF M 679cs

The Linhof M 679cs is packed and dispatched in an "intelligent box", called systainer with the following advantages:

No packing waste and the systainer offers a shock-resistant transportation facility accepting the camera with bellows plus back plus one lens, one adapter, one rollfilm magazine and the operating manual of the M 679. Furthermore, films can be stored.



The patented latch allows quick and safe linking of several systainers which can then be transported on a single handle.



The Systainer serves as transport packing and camera case.

When packing the camera for transportation with all adjustments in neutral position the rails should be set to the index marks on both sides approximately 5. The normal bellows, one lens mounted on lensboard as well as the ground-glass back can remain at the camera.

All knobs / clamping elements should be firmly but not excessively locked. The patented latch allows quick and safe linking of several systainers which can then be transported on a single handle for any further amount of accessories.

PLEASE NOTE:

When inserting the M 679cs into the sustainer case, please ensure the following:

1. All movements are set to zero.
2. The main track focusing should be set to 5 mm front and rear.
3. The red lock levers are facing upwards.

2.19. TRIPODS AND TRIPOD HEADS

Obviously, the selection of a tripod combination that matches the stability and precision of the camera is of vital importance.

For studio work a medium sized studio stand (Linhof Studiomatic I, 003467) is recommended with precision adjustable cross arm and accessory tray for magazines and backs.

For shooting on location we recommend the Linhof Twin Shank Pro Tripod (003317 or 003333).

For most tasks the M 679cs integrated levelling panorama benchholder will be sufficient. For extreme tiltings of the camera (more than 45°) we recommend the Linhof 3-Way Levelling Head (003663).



*Linhof 3-Way Levelling Head
(003663)*



*Linhof Twin Shank Pro Tripod
(003317 or 003333)*

3. LENSES AND SHUTTERS



Apo-Sironar-digital HR 4,5 / 28 mm in Copal shutter on recessed M 679 lensboard (001176) with cable release extension.



Apo-Digitar-Makro 5,6 / 120 mm in Copal shutter on flat lensboard (001160) with cable release extension.

Photographers who have so far worked with larger formats should note that in medium format photography identical focal lengths produce different results.

240 mm of the format 6x7 cm corresponds to a focal length of 450 mm when using the format 4x5 in. whereas a 120 mm lens is already a long focal length for the digital format 37x49 mm. Medium format photographers should know that lenses for images taken with adjustable cameras will need a larger image circle than those designed for non-adjustable medium format cameras. Only lenses with large image circles permit camera displacements. The angle of view is the key of different lens designs.

When using the rapid change adapter slide for „stitching“ images you have to control the image circle necessary for such multi exposures.

MAIN LENS CHARACTERISTICS

Focal length, aperture, size of shutter, diameter of filter (screw-in filter or slip-in filter) and image circle. For details please refer to the Linhof product and price listing or contact the lens manufacturer.

3.1. LENS SELECTION

As a general rule, three different lenses are considered the minimum in order to exploit the creative possibilities offered by cameras with adjustment facilities. The format diagonal of the picture format corresponds to the normal focal length (see sketch). The tables show the possible lens combination for the corresponding format.

For special applications also makro lenses 1 : 4 to 4 : 1, enlarging lenses or repro lenses can be used.

The new generation of digital lenses offer a specially high resolution necessary to produce optimum image information at small chip sizes in digital imaging technique.

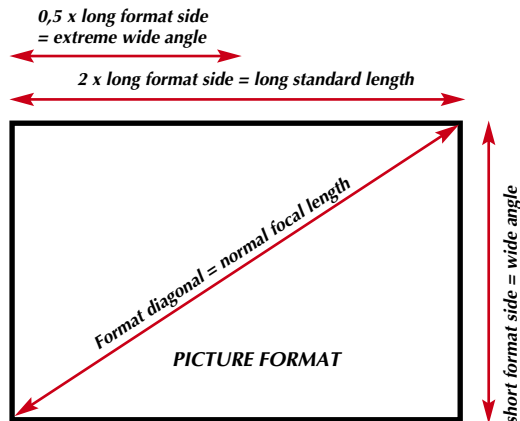

The table shows the context of the used picture format, the format diagonals and the corresponding focal lengths.

*Stitch: When using the Rapid Change Adapter Slide the image format and the corresponding image circle is enlarged is enlarged.

Picture Format digital	Format diagonal	Focal length		
		short	normal	long
30 x 30 mm	42 mm	24, 28, 35	45, 47, 55, 60	70, 72, 80, 90, 100
24 x 36 mm	43 mm	24, 28, 35	45, 47, 55, 60	70, 72, 80, 90, 100
63 x 36 mm stitch*	72 mm	35, 45, 47	72	100, 120, 150
49 x 37 mm	61 mm	35, 45, 47	55, 60, 72	100, 120, 150, 180
71 x 49 mm Stitch*	86 mm	35, 45, 55, 47	72, 80, 90, 100	120, 150, 180, 210

Picture Format analogue	Format diagonal	Focal length		
		short	normal	long
6 x 6 cm	85 mm	35, 38, 45, 47, 55, 58, 65	72, 75, 80, 90	100, 120, 135, 150
6 x 7 cm	91 mm	35, 38, 45, 47, 55, 58, 65, 72	75, 80, 90, 100	120, 135, 150, 180
6 x 8 cm	100 mm	35, 38, 45, 47, 55, 58, 65, 72, 75	80, 90, 100, 120	120, 135, 150, 180, 210
6 x 9 cm	108 mm	35, 38, 45, 47, 55, 58, 65, 72, 75, 80	90, 100, 120, 135	150, 180, 210, 240

The Linhof price and product listing contains the complete range of currently available lenses. For further details you should contact your Linhof experts.

3.2. IMAGE CIRCLE

In order to make optimum use of the decisive advantage of the M 679cs, i.e. its wide range of displacements lenses are needed with large image circle and first-class image reproduction quality right up to the edge of the image circle. The most important camera displacement is the parallel adjustment to eliminate or reduce converging verticals. For this, the lens must have an image circle far beyond the size of the taking format. The image circle stated in the technical specifications of the lens manufacturers always refer to a focusing distance of infinity and a working aperture of $f/22$. For shorter distances (e.g. for table shots), the image circle diameter will increase so that even larger adjustments are required. For digital lenses the corresponding working aperture is referred as $f/11$. The Linhof M 679cs offers the necessary long mechanical adjustment facilities.

Please always ensure that the image circle of the lens covers the mechanical displacements.

As a practical hint: when looking through the lens onto the groundglass at working aperture all four edges of the picture format have to be visible.

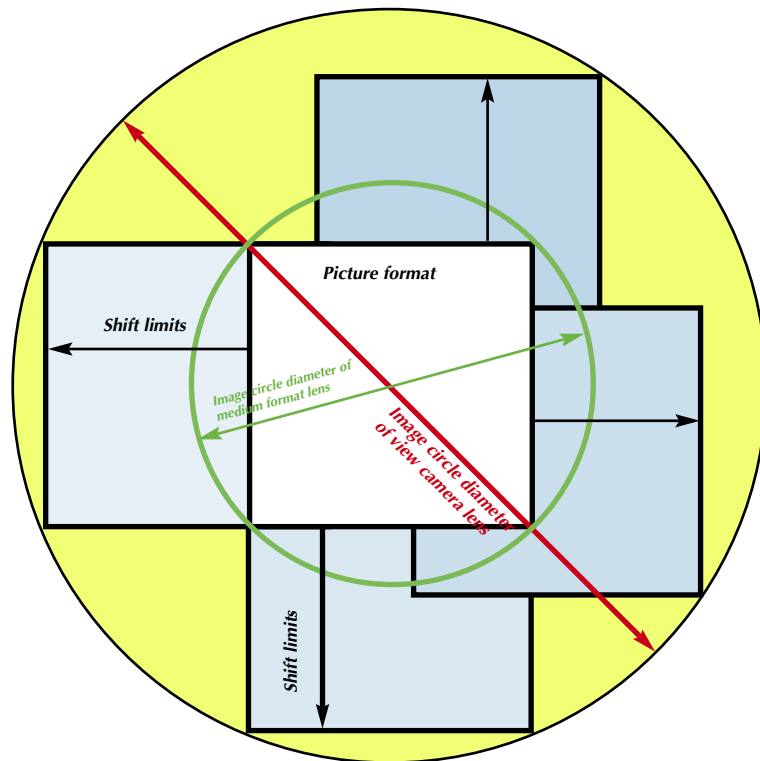

*Image circles and shift limits.
Within the limit of a sufficiently large image circle the picture format can be displaced.*

2.3. LENSBOARDS

The lensboards of the M 679cs are square accepting the lens exactly in the centre. According to focal lengths and lens design different lensboards are offered, flat or recessed with different holes corresponding to the required shutter sizes.

Left: flat lensboard, center: recessed lensboard, right: lensboard adapter for Technika 45 lensboards (001100)



With all symmetrically designed lenses (normally with lenses longer than 90 mm) the adjustment of the lens standard is effected by swinging around the principle point of the lens thus avoiding any movement of the picture. For the use of lenses already mounted on Technika 9x12 lensboard a special lensboard adapter is offered with the M 679cs.



4x Recessed Lensboard for Apo-Digitar XL 5,6/35 in Copal Shutter

This lensboard (001178) allows the use of the 5,6/35 mm lens in Copal shutter with the Linhof M 679cs including the Rapid Change Adapter Slide. The decisive advantage is the availability of an increased omni directional shift range of 12 mm.

Despite of the depth of the recessed board an easy and comfortable shutter operation is provided thanks to the re-arrangement of the release lever and aperture scales.

3.4. SHUTTERS

The shutter of a lens controls the exposure, i.e. aperture and time.

We offer all lenses in central mechanical and electronically controlled shutters which can also be mounted by Linhof on the corresponding lensboards.

Mechanical Copal shutters

Central shutters with stepless adjustment or adjustment in increments.

Copal size 0: 1 – 1/500s + B + T

Copal size 1: 1 – 1/400s + B + T

Electronic shutters

Electronically controlled shutters enable easy control via computer software thus utilizing all features of one-shot or multi-shot digital backs. These electronic shutters offer considerably more „increments“ for aperture and controlled time exposure.

The Rollei electronic view camera shutter

Electronically controlled via remote control
Rollei LensControl S. Sizes 0 and 1.

Shutter speeds B and 30s to 1/500s in third-stop increments.

In tenth-stop increments adjustable 5-blade-iris aperture. Weight 306 g.

Schneider Electronic shutter

This is electronically controllable via the computer. Size 0. Shutter speeds B and 32s to 1/60s in tenth-stop increments adjustable 5-blade-iris aperture. Weight 180 g.



Schneider electronic shutter and shutter control with Linhof M 679cs and digital back.



Digital lenses on Linhof M 679 lensboards ranging from 24 to 210 mm focal lengths in electronic or mechanical shutters (Rollei, Schneider, Copal).

3.5. DIGITAL LENSES

The lens is an important link of the quality chain in professional photography.

Digital lenses adjusted to the needs of digital imaging technique offer optimum sharpness fully utilizing the high resolution chip sensors. These lenses meet high quality requirements concerning contrast, correction of distortion and absence of color fringes.

New digital wide angle lenses with image circles from 60 to 110 mm have the capacity for adjustment, correction of perspective, „converging lines“ as well as for depth of field control according to the Scheimpflug law.

For close-up and makro photography there exist special makro lenses optimized for a 1 : 1 and higher reproduction ratio.

The full range of available digital lenses can be found in the current Linhof price and product listing.

4. CAMERA ADJUSTMENTS

Only by the possibility of displacing lens and rear standard all advantages of a view camera are fully utilized. These displacements serve for control of perspective, positioning of the depth-of-field and creative image composing. Any camera displacement requires the appropriate lens with the sufficient image circle. Before starting to use camera movements, return all camera controls to zero.

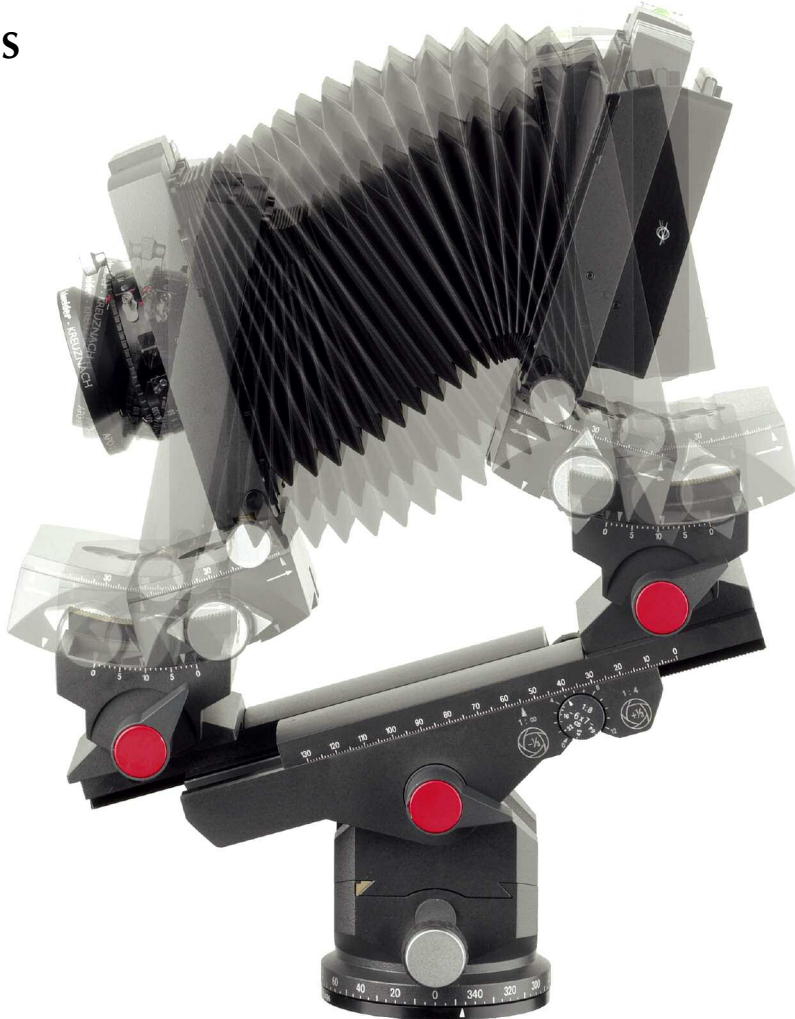

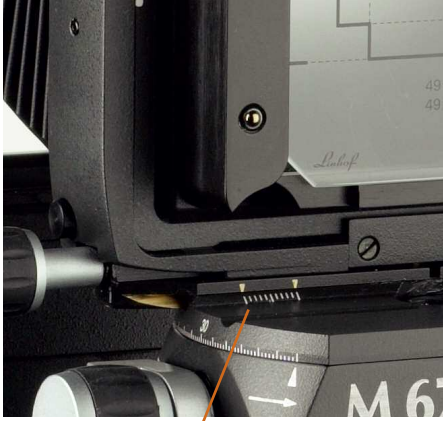

Scale for lateral shift at the rear standard

Direct parallel adjustment (vertical shift) with self aligning micro drives at the lens standard (M 679cs with Apo-Sironar 4,5/35 mm and wide angle bellows).



4.1. VERTICAL AND LATERAL SHIFT (DIRECT DISPLACEMENT)

Horizontal and vertical parallel displacements are operated with self-aligning micro drives. Direct adjustments are recommended for precise cropping corrections and should normally be made after having finished all settings thus avoiding any movement of the tilting axis out of their centre position .

When working with extremely short lenses (24, 28, 35, 38 mm) we recommend the direct camera displacement using the horizontal and vertical shift facilities. In general their range of adjustment is sufficient and all displacements remain parallel.

4.2. INDIRECT PARALLEL DISPLACEMENTS

Parallel movements (rise and shift of the front and back standards) are primarily used to eliminate converging verticals or horizontals in subjects with predominantly parallel lines. While vanishing lines are simply the normal perspective rendition resulting from an oblique position of the image plane relative to the main subject plane, the experienced professional will see that through proper use of camera adjustments pictures do not show any of the unwanted perspectives so often found in architectural and industrial subjects.

Whether up, down or lateral shift of the lens or rear standard:
Most parallel adjustments are executed indirectly.

In other words:

The front and rear standard is simply placed parallel to the main view of the subject.

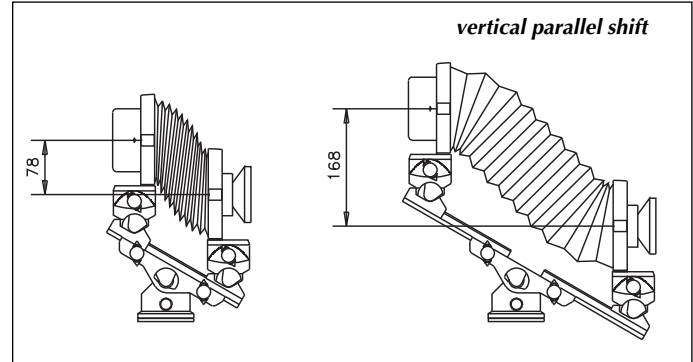

The possible adjustments increase linear with the camera extension. The M 679cs offers an up/down or lateral shift of 168 mm each at maximum camera extension (tilting angle 30°). At minimum camera extension the possible indirect parallel shift is approximately 38 mm. The sketch shows extension and adjustment which can be achieved with normal bellows.

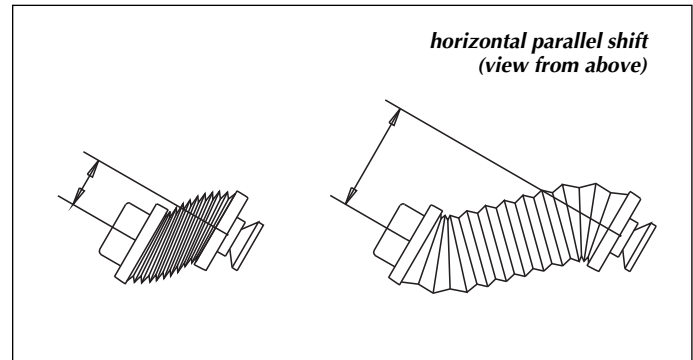

4.3. VERTICAL PARALLEL SHIFTS (INDIRECT)

Indirect vertical shifts (lens rise or lens drop) are used to produce an image without converging lines when shooting from a low or high view point.

LENS RISE:

With all adjustments in neutral position and with the aid of the integrated panorama benchholder the camera is set to the subject. Focus until the object appears in focus on the groundglass. Adjust lens and rear standards to vertical with the aid of the spirit level. If necessary, refocus. The picture was taken with a 58 mm wide angle lens.

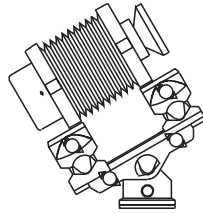

1. Set the camera to the subject, composing the image.

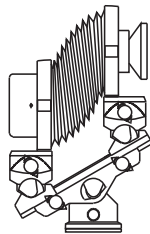

2. Adjust lens and rear standards to vertical with the aid of the spirit level, if necessary make cropping correction, focus.



LENS DROP

When working in the studio shooting is often made from a high view point (still life, table-tops etc.): with the aid of the integrated panorama benchholder the camera is set to the subject determining the image on the groundglass and focus. Adjust front and rear standards to vertical with the aid of the spirit level, refocus.

REMAINING PERSPECTIVE

Since totally corrected images can sometimes appear unreal a so-called "remaining perspective" is often desirable. This is an uncomplicated procedure: read off the angle of tilting of the optical bench and reduce the base tilt of the standard by approximately 25%.

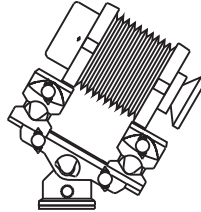

1. Set the camera to the object, frame the image.
The package is seen with converging verticals.

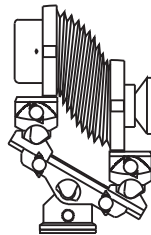
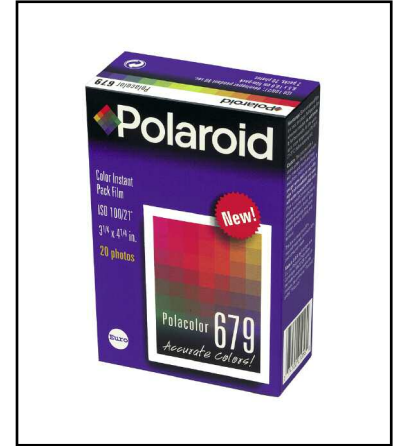

2. Adjust front and rear standard to vertical with the aid of the spirit level.
The package is seen with undistorted verticals.

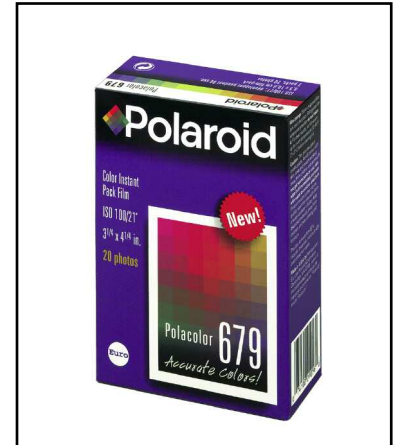

4.4. HORIZONTAL PARALLEL SHIFTS

Horizontal shifts (lateral displacement or cross front movements) are used to obtain frontal views from a lateral camera position, producing an image without vanishing lines and perspective distortion. This is a common requirement when standing in front of reflecting surfaces (mirrors, windows) or when the view from a centre position directly in front of the subject is obstructed or includes unwanted subject matter. To ensure correct perspective, start by placing the camera (and the filmplane) parallel to the main object plane:

The camera has to be rotated with the bench panorama holder to the object until reaching the desired framing on the groundglass. Then turn the back standard around the vertical axis until you reach the main view of the object preferably utilizing the grid lines of the ground-glass. Now transfer the angle of rotation of the panorama of the rear standard to the lens standard for obtaining exact parallelism.



1. Shooting with non-displaced camera:
the main view shows converging lines.

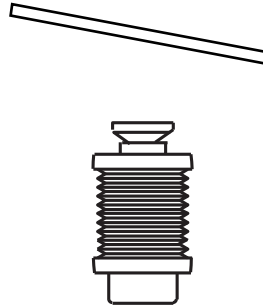

1a. Set camera to the object, frame the image
(camera is shown from above).

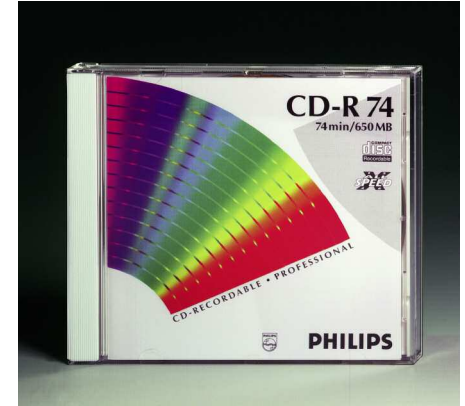

2. Shooting with camera and parallel adjustments:
the main view is seen undistorted.

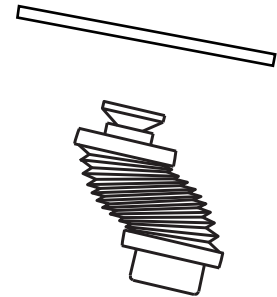

2b. Adjust rear standard parallel to main view.
Transfer angle to lens standard.

4.5. COMBINED PARALLEL SHIFTS

Horizontal and vertical shifts can, of course, also be applied in combination.

A typical example is the reproduction of a package where the front cover is to be shown as a rectangle and both the top and the side should be visible as well.

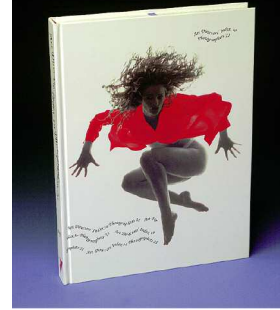
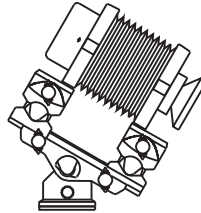

1. Select the appropriate camera view point, adjust the groundglass, determine framing.

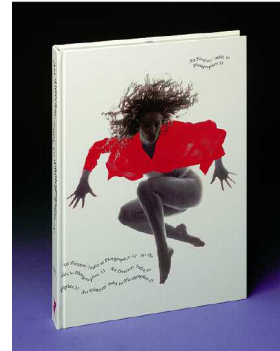
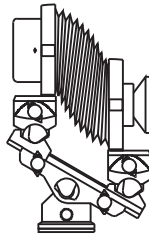

2. Adjust both standards vertically with the aid of the spirit level for avoiding converging lines.

PRACTICAL HINT:

All camera adjustments should start at the panorama benchholder (1). Then follows - if necessary - the adjustment of the standards to vertical. All control elements are situated above the panorama benchholder at the optical bench (2). The final adjustment facilities (level 3) for the camera are swings and tilts by rack and pinion drives. Finally the cropping correction is made (4).

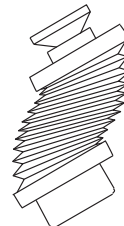
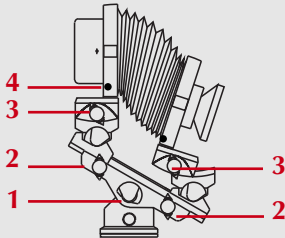

3. Swing rear standard for parallel position to the book cover. Set camera to grid net lines of the groundglass. Read off angle and transfer to the lens standard. Refocus (illustration shows camera from top). Make cropping correction when necessary.

4.6. SCHEIMPFLUG ADJUSTMENTS

When talking about camera movements, the term "Scheimpflug" is often subject to a certain amount of misinterpretation. Even by experienced photographers, the use of Scheimpflug adjustments to control focus and depth-of-field is either looked upon as a highly complex mathematical problem or considered a simple adjustment procedure which a modern view camera should do more or less automatically by itself. Neither opinion really corresponds with the photographic practice, as the truth is somewhere in the middle, but once there is a certain understanding of the theory behind all Scheimpflug adjustments, their practical application becomes as simple and fool proof routine.

THE SCHEIMPFLUG RULE

To provide sharp focus over the entire picture when main object plane is at an angle to the camera, the object main plane, the lens plane and the image plane must intersect in one common line.

This rule can be applied by swinging the groundglass or (and) the lens standard.

Scheimpflug by swinging the lens standard does not alter the given perspective "consuming" however much of the image circle (limits of the

adjustment possibilities). Groundglass-Scheimpflug exaggerates the perspective rendition but "saves" image circle.

PRACTICAL PROCEDURE

Before starting with any Scheimpflug adjustments, the plane of sharp focus running from the near to the far object point should be determined. The most simple application can be found with two dimensional objects, such as plane of table, carpet, meadows or wall: the main object plane has a certain angle to the image plane. First determine one near object point and one far object point of the object plane. Near and far object point should be seen

on the opposite side of the groundglass. The amount and direction to any camera adjustment required to fulfill the Scheimpflug condition can easily be determined by looking at the camera and the subject from the side. It will be seen that the more distant objects in the infinity range (buildings) require relatively small adjustments of a few degrees which will steadily increase with closer focusing distances. In extreme close-up work, with reproduction ratios between 1:4 and natural size 1:1, the amount of swings or tilts needed will often require the adjustments of both the front and the rear standard (for instance small table-top subjects, tools, electronic components and assemblies etc.).

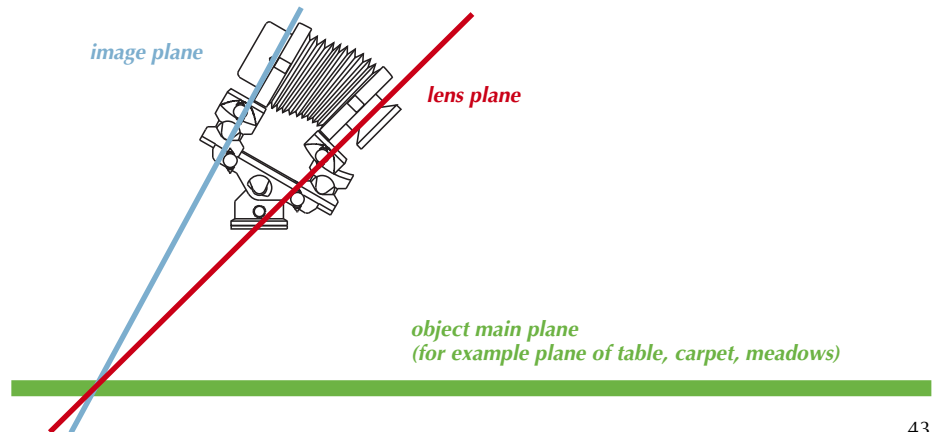

DISPLACEMENTS, WHERE?

The M 679 with its highly practical centre rotation of the lens standard, also allows direct Scheimpflug adjustments with the front simply by focusing to the near object point and swinging/tilting the lens standard until also the far object point comes into focus. As a result of the centre rotation, only a slight focus adjustment will become necessary.

DOUBLE SCHEIMPFLUG

There are many objects where the desired sharpness is in an oblique plane. In this case, both axis - the vertical and the horizontal axis - have to be swung.

First swing the horizontal or lateral axis, then swing around the vertical axis in order to avoid any yawing.

By swinging of the image and lens plane any desired focal plane can be achieved.

Displacement with rear standard:

- + only slight focusing necessary
- + desired plus of perspective rendition
- + centre raise of the lens are used: positive for a clear quality of the image
- + extremely simple control of depth-of-field: turning axis always remains in focus
- distortions unavoidable
- rays do not meet the groundglass centrally thus complicating the viewing of the image

Displacement with the lens standard:

- + no perspective distortion
- + easy viewing of the image on the groundglass
- refocusing necessary during adjustments
- border rays of the lens will be used, i.e. the limit of the image circle is quickly reached. Vignetting is possible

Utilizing the advantages of both procedures:

1. Displacements with the rear standard - centre of groundglass remains in focus.
2. Angle value is transferred to lens standard (reduced by angle value of adjustment in per cent values), swing in opposite direction, refocus.

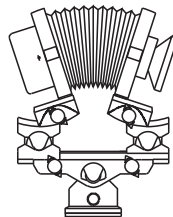

Displacements with rear **and** lens standard: Tilting at the horizontal axis

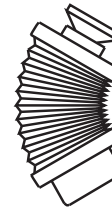

Displacements with rear **and** lens standard: swinging around the vertical axis (illustration shows camera from above).

PPRACTICAL EXAMPLE

The design of the M 679cs permits turning and swinging of the lens in the principle point (focal length over 90 mm). Tilting and swinging of the groundglass is made exactly in the horizontal and vertical axis. This design therefore permits the easy use of the Scheimpflug rule (the example shows a typical still life situation in the studio).

This systematic operation can, of course, be facilitated by starting to swing the lens standard. In this case, however, continue as refocusing is necessary.

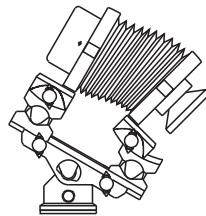
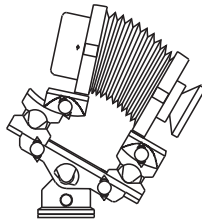
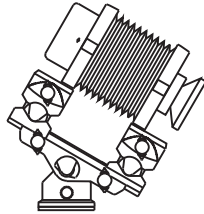

1. Set the camera with the panorama bench-holder to the object. If possible focus an object point (M) on the groundglass axis (swinging axis) which should be in the desired focal plane.
2. Now, swing rear standard toward the expected direction until the near and far point become simultaneously sharp (N + F both in the desired plane). The Scheimpflug adjustment is made. The plane of sharpness runs from the foreground to the background. But the foreground is still distorted.
3. Whilst maintaining the perspective rendition the tilting angle of the rear standard is transferred to the lens standard reduced by the percentage of angle value. For example: the tilting angle of the rear standard is 18°, minus 18% of 18 (approximately 3), results into the required angle of the lens standard of 15°. The rear standard will then be reset to zero. Finally, refocus.

4.7. DEPTH-OF-FIELD WEDGE

Since the objects to be handled are normally 3-dimensional you have to use additionally a small lens aperture.

Example: The height of a building is the area of the required depth-of-field. In order to reach this position with the smallest possible lens aperture the focal plane is set in such a way that the object is intersected in the centre as the depth-of-field zone, which extends to either side of the plane of focus, increases uniformly. The area of the depth-of-field is like a wedge. This will become smaller when being nearer to the camera. Table-top shooting with increased depth-of-field necessitate placing flat objects near to the camera whereas higher objects should be placed in a more distant position of the camera. Most still lifes are typical examples.

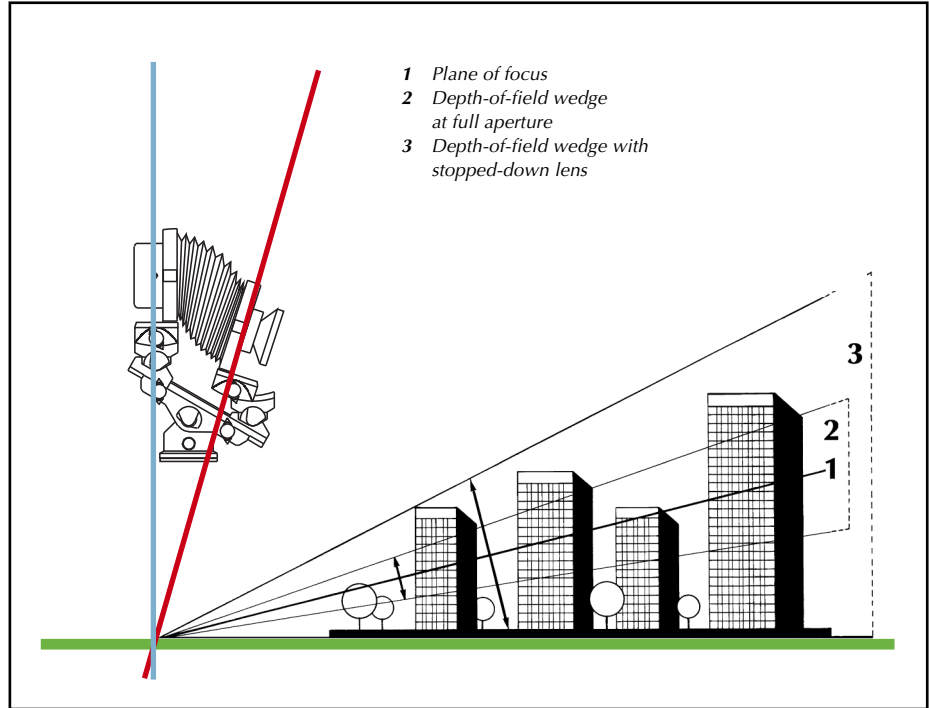

How to gain depth-of-field

As the depth-of-field zone, which extends to either side of the plane of focus, increases uniformly when the lens is stopped down, it is important to adjust the camera in such a way that the plane of focus runs through the middle of the object. Since the depth-of-field increases at same aperture with increasing distance from the camera, a wedge type area for the sharpness is the result.

4.8. SUMMARY

1. Use Scheimpflug adjustments for depth-of-field control only for subjects which are in an oblique position to the camera from the near point to the far point.
2. Without stopping down only 2-dimensional subjects (carpets, walls etc.) will have an overall sharpness.
3. Scheimpflug adjustments are a logical way to control depth-of-field as long as there is one major and clearly defined plane of focus.
4. If overall sharpness over an expanded 3-dimensional space without clearly defined sharpness planes is required, this can only be achieved in the conventional way through a correspondingly small lens aperture as determined by a suitable depth-of-field calculator.



Typical studio situation

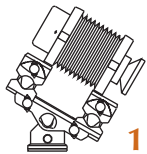

1

With the aid of the integrated panorama tilt head the camera is set to the object.

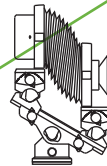

2

To avoid converging vertical details lens and rear standard are adjusted to vertical with the aid of the spirit level.

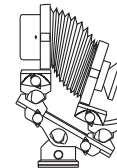

3

Scheimpflug for increased depth-of-field. In this case, the lens standard has to be tilted. Use micro drives for direct vertical and lateral shifts. Determine depth-of-field and aperture with the aid of the depth-of-field optimizer.

4.9. DEPTH-OF-FIELD AND DEPTH-OF-FIELD OPTIMIZER

Generally speaking, only one plane can remain sharp. Everything behind or before becomes increasingly unsharp. The area the photographer is not visualizing this sharpness is called depth-of-field. This depth-of-field is based on the following factors:

1. Reproduction range.

The smaller the reproduction range, the larger the depth-of-field area.

2. Stopped-down lens.

The more the lens is stopped down, the larger is the depth-of-field.

Please observe that the physically given defraction of the lenses result into a decrease of the lens performance. Therefore, never stop down too much if unnecessary.

The general rule for the ideal point of focus with a desirable depth-of-field zone is: Focus on 50% of the difference of the camera extension, i.e. on the middle between near and far point focusing of the camera.

Depth-of-field optimizer

The M 679cs offers an integrated depth-of-field optimizer. For the depth-of-field optimizer, interchangeable format dials are available:

- Format dial 3x3 for digital backs, chip size from 24x26 to 37x49 mm
- Format dial 6x7 for formats 6x6 – 6x8 cm (included in camera price)
- Format dial 6x9 cm

If the optical bench is tilted more than 20° the calculated aperture value can be reduced by 1/3 f/stop.

If the depth-of-field requirements result in an excessively large extension difference, try to reduce the distance by re-arranging the depth-of-field zone using Scheimpflug adjustments. Sometimes it is necessary to increase the taking distance to eliminate or reduce depth-of-field problems.

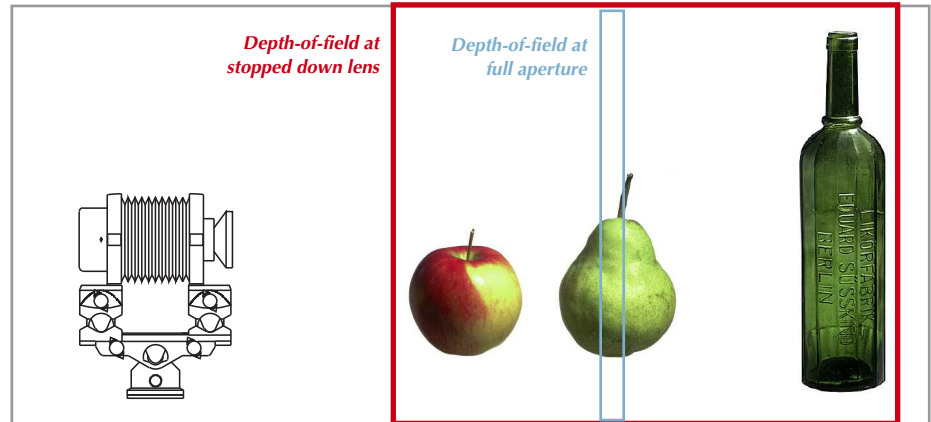

When stopping down a non-displaced camera the depth-of-field increases more in the background than in the foreground depending on distance and aperture.

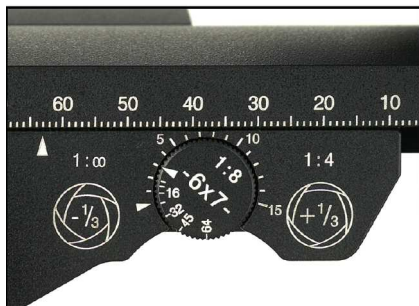
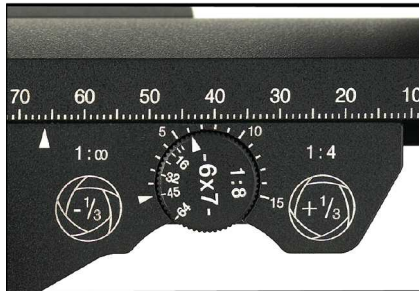
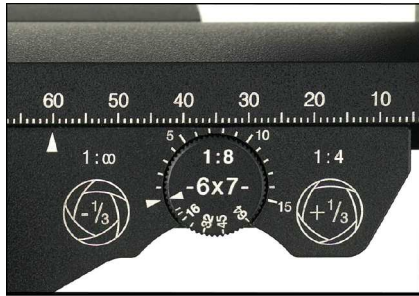

Here is how it works:

1. Focus on the most distant subject point, rotate format equivalent dial triangle on triangle to basic position (illustration shows format 6x7).
2. Focus on the near point of the subject (triangle in the illustration = 6).
Read off the working aperture on the dial opposite to the triangle (here 45) and set the lens accordingly. The optimizer is calculated for a reproduction range of 1 : 8.
Reproduction range 1 : 4 = + 1/3 stop (32 2/3),
1 : infinity = - 1/3 stop (45 1/3).
3. Refocus to half of the extension value shown or 2 f stops (triangle in the illustration = 3 or f 22).
Lock integrated lever of focusing knob.
The optimum sharpness is found.

CLOSE-UP FOCUSING

Focusing of studio cameras is normally handled with the rear standard. However, a reproduction range of 1:1 requires enormous displacements even for smaller depth-of-field operations. In this case, focusing with the lens standard is strongly recommended which changes not only the front focal distance but also the image distance (increasing focal distance = diminishing image distance and vice versa). By doing this, focusing is faster with less movements. Thanks to the adjustment technique by identical rack and pinion comfort and identical precision micro drives and clamping elements for both standard rails the Linhof M 679cs fully supports this technique. Only the final focusing on the most distant subject point and the near point of the subject for finding of the optimum aperture at the aperture dial is effected with the back standard.

4.10. WHAT ABOUT YAWING

Yaw can occur when a camera system does not allow the photographer to adjust the standards to a vertical position after inclining the monorail. In this case yawing occurs with indirect displacements and the use of the Scheimpflug rule, with the result that one or both standards swung around their axis in a non-vertical position, reduce the sharpness, and adjustments already made cannot be fully utilized. The design of the Linhof M 679cs will always avoid yawing when correctly handled: with indirect up and down shifts, tilted base and vertical standards, the standards will always remain vertical. When adjusting according to the Scheimpflug rule such as tilting or turning

the lens around the center axis the depth-of-field zone will always be clearly defined and controlled.

When utilizing double Scheimpflug with the M 679cs the rule is: right before left.

This means: first tilt the horizontal axis with the aid of the micro drives situated on the right side. Then rotate around the vertical axis.

The operating elements are now on the left side of the camera (seen from the groundglass).

This sequence is also necessary for lateral indirect parallel displacements and necessary Scheimpflug around the horizontal axis - first finish your adjustments according to Scheimpflug, then adjust the standards to parallel.



4.11. VIEW CAMERA MOVEMENTS MADE SIMPLE

View camera adjustments become less complicated if you stick to a predetermined method of operation taking into account the following rules.

- Before starting to use camera movements, return all camera controls to zero.
 - Framing with the M 679cs is as easy as with a non-adjustable medium format camera: set the camera to the object.
If necessary: adjust lens and rear standard to vertical with the aid of the spirit level or swing the standards around the vertical axis.
 - If an image with parallel lines and right angles is required: align camera/groundglass so that it is parallel to the main subject front.
 - Use Scheimpflug adjustments for depth-of-field control, if necessary. Scheimpflug can only help if one dimension of the subject is dominating (for example flat tart). With uniform bodies (for example ball, cube) Scheimpflug will not necessarily be advantageous unless one plane is of priority.
- In the event that a shot needs to be marginally re-framed after composition this can easily be done by direct cropping correction.
 - Still missing depth-of-field can now only be reached by stopping down of the lens.
 - Focus precisely with the aid of the depth-of-field optimizer calculating the necessary aperture.
 - If required depth-of-field cannot be obtained, the reproduction ratio should be changed by increasing the focal distance.
 - Should a certain combination of camera movements fail to produce the desired effect, a solution will often be found by returning all adjustments to zero and repeating the above procedure.
 - After any adjustment made precise locking is required, however, do not clamp the micro drives too extensively. The red locking levers for panorama benchholder and the standards should be carefully tightened.



LINHOF PRÄZISIONS-SYSTEMTECHNIK GMBH
RUPERT-MAYER-STRASSE 45
81379 MÜNCHEN
GERMANY

TEL. +49.89.724920
FAX +49.89.72492250
www.linhof.de
info@linhof.de